



User Guide

SM-SLM

Solutions Module for:
Unidrive SP
Digitax ST

Part Number: 0471-0035-06

Issue Number: 6



General Information

The manufacturer accepts no liability for any consequences resulting from inappropriate, negligent or incorrect installation or adjustment of the optional parameters of the equipment or from mismatching the variable speed drive with the motor.

The contents of this guide are believed to be correct at the time of printing. In the interests of commitment to a policy of continuous development and improvement, the manufacturer reserves the right to change the specification of the product or its performance, or the content of the guide without notice.

All rights reserved. No parts of this guide may be reproduced or transmitted in any form or by any means, electrical or mechanical including, photocopying, recording or by an information storage or retrieval system, without permission in writing from the publisher.

Environmental Statement

Control Techniques is committed to minimising the environmental impacts of its manufacturing operations and of its products throughout their life cycle. To this end, we operate an Environmental Management System (EMS) which is certified to the International Standard ISO 14001. Further information on the EMS, our Environment Policy and other relevant information is available on request, or can be found at www.greendrives.com.

The electronic variable speed drives manufactured by Control Techniques have the potential to save energy and (through increased machine/process efficiency) reduce raw material consumption and scrap throughout their long working lifetime. In typical applications, these positive environmental effects far outweigh the negative impacts of product manufacture and end-of-life disposal.

Nevertheless, when the products eventually reach the end of their useful life, they must not be discarded but should instead be recycled by a specialist recycler of electronic equipment. Recyclers will find the products easy to dismantle into their major component parts for efficient recycling. Many parts snap together and can be separated without the use of tools, whilst other parts are secured with conventional fasteners. Virtually all parts of the product are suitable for recycling.

Product packaging is of good quality and can be re-used. Large products are packed in wooden crates, while smaller products come in strong cardboard cartons which themselves have a high-recycled fibre content. If not re-used, these containers can be recycled. Polythene, used on the protective film and bags from wrapping product, can be recycled in the same way. Control Techniques' packaging strategy prefers easily recyclable materials of low environmental impact, and regular reviews identify opportunities for improvement.

When preparing to recycle or dispose of any product or packaging, please observe local legislation and best practice.

Software Statement

This Solutions Module (SM) is supplied with the latest software version. When retro-fitting to an existing system, all software versions should be verified to confirm the same functionality as Solutions Modules of the same type already present. This also applies to products returned from a Control Techniques Service Centre or Repair Centre. If there is any doubt please contact the supplier of the product.

The software version of the Solutions Module can be identified by looking at Pr **MM.02** and Pr **MM.51**, where **MM** is the relevant menu number for the Solutions Module slot being used.

See Pr **MM.02** and Pr **MM.51** description later in this manual for more information.

The software version takes the form of xx.yy.zz, where Pr **MM.02** displays xx.yy and Pr **MM.51** displays zz (e.g. for software version 01.01.00 Pr **MM.02** will display 1.01 and Pr **MM.51** will display 0).

REACH legislation

EC Regulation 1907/2006 on the Registration, Evaluation, Authorisation and restriction of Chemicals (REACH) requires the supplier of an article to inform the recipient if it contains more than a specified proportion of any substance which is considered by the European Chemicals Agency (ECHA) to be a Substance of Very High Concern (SVHC) and is therefore listed by them as a candidate for compulsory authorisation.

For current information on how this requirement applies in relation to specific Control Techniques products, please approach your usual contact in the first instance. Control Techniques position statement can be viewed at:

<http://www.controltechniques.com/REACH>

Copyright : © July 2009 Control Techniques Ltd.

Issue Number : 6

Contents

1	About this guide	4
1.1	Intended personnel	4
1.2	Information	4
2	Safety information	5
2.1	Warnings, Cautions and Notes	5
2.2	Electrical safety - general warning	5
2.3	System design and safety of personnel	5
2.4	Environmental limits	6
2.5	Compliance with regulations	6
2.6	Motor	6
2.7	Adjusting parameters	6
3	Introduction	7
3.1	Operating modes	7
3.2	Features	7
3.3	Solutions Module identification	11
3.4	Set-up parameters	11
4	Installation	12
4.1	Installing the SM-SLM	12
4.2	Installation	13
4.3	Terminal descriptions	15
4.4	Power supplies	16
4.5	Wiring, Shield connections	16
5	Getting started	20
5.1	Installation	20
5.2	Encoder only mode	21
5.3	External-host mode - Torque-amplifier only	27
5.4	Sequencer (Encoder only mode and External-host mode)	32
6	Advanced setup	35
6.1	SM-SLM and SLM EEPROM (CT Coder) set-up (Advanced user)	35
6.2	Altering the SLM EEPROM (CT Coder) Motor Object and Unidrive SP / Digitax ST Object	36
7	Parameters	37
7.1	Introduction	37
7.2	Single line descriptions	38
7.3	Parameter descriptions	42
8	Diagnostics	52
8.1	Displaying the trip history	52
9	Terminal data	56
9.1	SLM port	56
9.2	MC port	56
9.3	5-way terminal	57
	Index	58

1 About this guide

1.1 Intended personnel

This guide is intended for personnel who have the necessary training and experience in system design, installation, commissioning and maintenance.

1.2 Information

This guide contains information covering the identification of the Solutions Module, terminal layout for installation, fitting of the Solutions Module to the drive, parameter details and diagnosis information. Additional to the aforementioned are the specifications of the Solutions Module.

2 Safety information

2.1 Warnings, Cautions and Notes



A **Warning** contains information, which is essential for avoiding a safety hazard.



A **Caution** contains information, which is necessary for avoiding a risk of damage to the product or other equipment.

NOTE A **Note** contains information, which helps to ensure correct operation of the product.

2.2 Electrical safety - general warning

The voltages used in the drive can cause severe electrical shock and/or burns, and could be lethal. Extreme care is necessary at all times when working with or adjacent to the drive.

Specific warnings are given at the relevant places in this User Guide.

2.3 System design and safety of personnel

The drive is intended as a component for professional incorporation into complete equipment or a system. If installed incorrectly, the drive may present a safety hazard.

The drive uses high voltages and currents, carries a high level of stored electrical energy, and is used to control equipment which can cause injury.

Close attention is required to the electrical installation and the system design to avoid hazards either in normal operation or in the event of equipment malfunction. System design, installation, commissioning and maintenance must be carried out by personnel who have the necessary training and experience. They must read this safety information and this User Guide carefully.

The STOP and SECURE DISABLE functions of the drive do not isolate dangerous voltages from the output of the drive or from any external option unit. The supply must be disconnected by an approved electrical isolation device before gaining access to the electrical connections.

With the sole exception of the SECURE DISABLE / SAFE TORQUE OFF function, none of the drive functions must be used to ensure safety of personnel, i.e. they must not be used for safety-related functions.

The SECURE DISABLE or SAFE TORQUE OFF function is only available as standard on the Unidrive SP or Digitax ST. Respectively the Affinity and Commander SK drives do not have a secure disable feature.

The SECURE DISABLE function on Unidrive SP and the SAFE TORQUE OFF function on Digitax ST meet the requirements of EN954-1 category 3 for the prevention of unexpected starting of the drive. They may be used in a safety-related application. **The system designer is responsible for ensuring that the complete system is safe and designed correctly according to the relevant safety standards.**

Careful consideration must be given to the functions of the drive which might result in a hazard, either through their intended behavior or through incorrect operation due to a fault. In any application where a malfunction of the drive or its control system could lead to or allow damage, loss or injury, a risk analysis must be carried out, and where necessary, further measures taken to reduce the risk - for example, an over-speed protection device in case of failure of the speed control, or a fail-safe mechanical brake in case of loss of motor braking.

2.4 Environmental limits

Information contained in both the *Unidrive SP User Guide* and the *Digitax ST Technical Data Guide*, regarding transport, storage, installation and use of the drive must be complied with, including the specified environmental limits. Drives must not be subjected to excessive physical force.

2.5 Compliance with regulations

The installer is responsible for complying with all relevant regulations, such as national wiring regulations, accident prevention regulations and electromagnetic compatibility (EMC) regulations. Particular attention must be given to the cross-sectional areas of conductors, the selection of fuses or other protection, and protective ground (earth) connections.

The *Unidrive SP and Digitax ST User Guides* contain instructions for achieving compliance with specific EMC standards.

Within the European Union, all machinery in which this product is used must comply with the following directives:

98/37/EC: Safety of machinery.

2004/108/EC Electromagnetic Compatibility.

2.6 Motor

Ensure the motor is installed in accordance with the manufacturer's recommendations. Ensure the motor shaft is not exposed.

Standard squirrel cage induction motors are designed for single speed operation. If it is intended to use the capability of the drive to run a motor at speeds above its designed maximum, it is strongly recommended that the manufacturer is consulted first.

Low speeds may cause the motor to overheat because the cooling fan becomes less effective. The motor should be installed with a protection thermistor. If necessary, an electric forced vent fan should be used.

The values of the motor parameters set in the drive affect the protection of the motor. The default values in the drive should not be relied upon.

It is essential that the correct value is entered in the motor rated current parameter: Pr **0.46** for Unidrive SP/Digitax ST. This affects the thermal protection of the motor.

2.7 Adjusting parameters

Some parameters have a profound effect on the operation of the drive. They must not be altered without careful consideration of the impact on the controlled system. Measures must be taken to prevent unwanted changes due to error or tampering.

3 Introduction

3.1 Operating modes

The SM-SLM allows SLM feedback to be connected directly to the Unidrive SP / Digitax ST drives, and allows operation in either of the following two modes:

- Encoder only mode
- External-host mode

3.2 Features

The SM-SLM can be configured for either reference or main feedback while in Encoder only mode. In External-host mode it must be used as the main feedback.

A total of three Solutions Modules can be fitted to the drive at any one time in Encoder only mode, with these being used for position and speed feedback. For External-host mode, only one SM-SLM can be fitted. Any additional modules would have to be configured in Encoder only mode.

Figure 3-1 SM-SLM

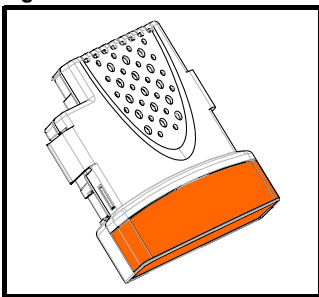

NOTE The SM-SLM can only be used with Unidrive SP drive software version 1.07.00 onwards.

NOTE Unidrive SP can only be used with SM-SLM software version 01.02.00 onwards.

NOTE Digitax ST can only be used with SM-SLM software version 01.04.00 onwards.

NOTE Due to the SM-SLM operating at a fixed baud rate, there is a restricted allowable maximum cable length: 50m (total length from SLM to drive to host controller).

3.2.1 Encoder only mode

In Encoder only mode, the Unidrive SP / Digitax ST acts as a standard drive with its own position, speed and torque loop fully operational. In this configuration the Unidrive SP uses the SLM speed feedback in either closed loop vector or servo mode, whereas the Digitax ST uses the SLM speed feedback in servo mode only.

NOTE In Encoder only mode, no motion controller can be connected to the SLM. If connected, a DriveLink error will occur.

Figure 3-2 Unidrive SP / Digitax ST host controller

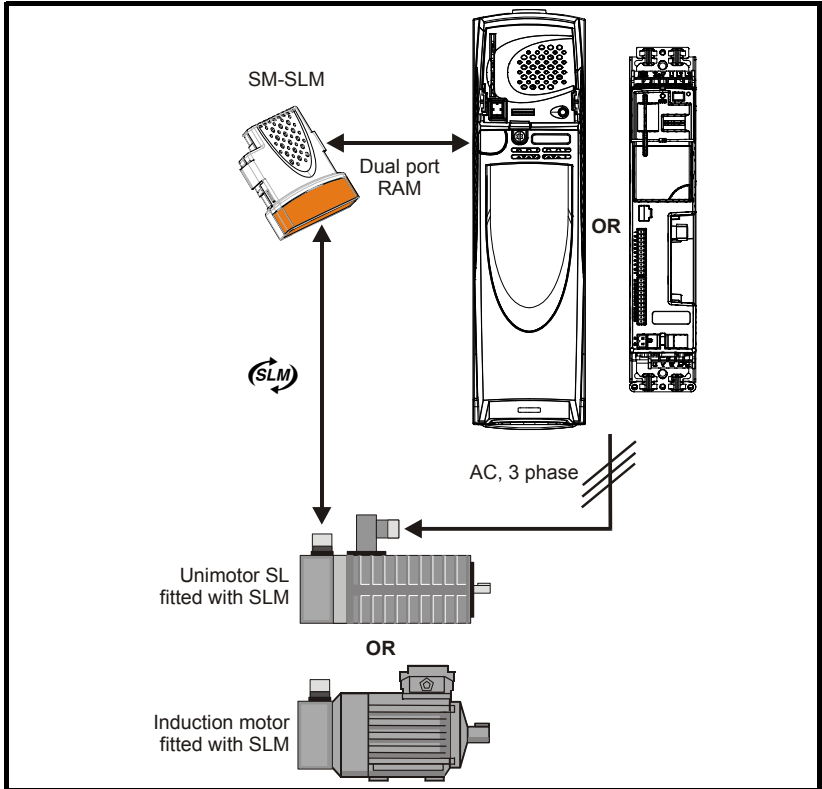

In this configuration the Unidrive SP / Digitax ST drive functions as the host, with its own position, speed and torque loop.

Figure 3-3 SM-Applications, PC or non-SLM motion controller being host

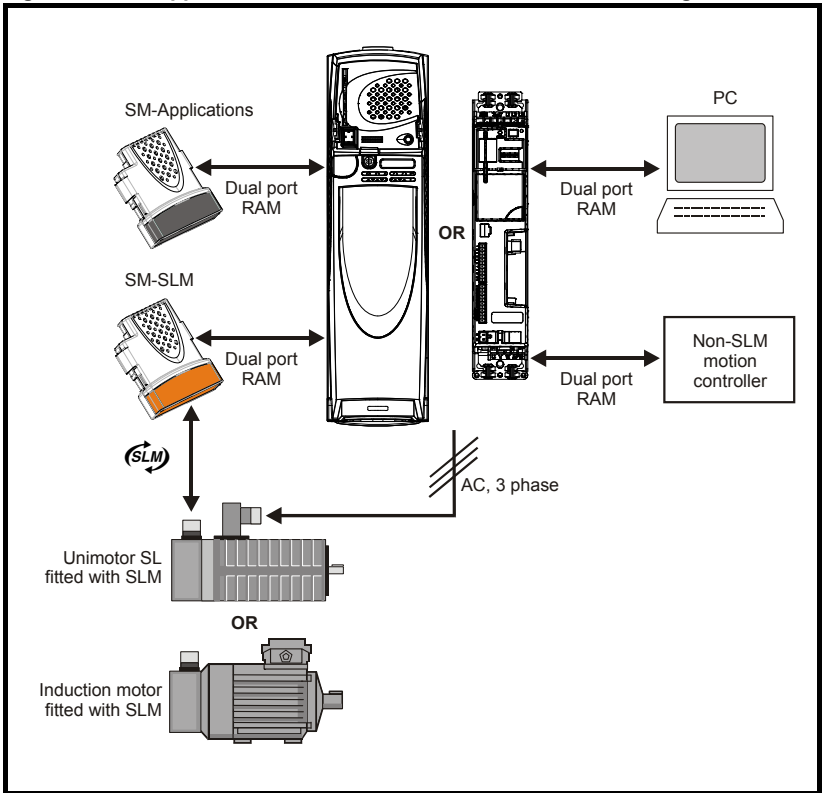

In the above configuration, both the Unidrive SP / Digitax ST drive's speed loop and torque loop are being utilized. However, the position control is carried out by either:

1. SM-Apps Lite / Apps Plus
2. PC
3. Non SLM-motion controller (e.g. through SM-PROFIBUS-DP)

About this guide
Safety information
Introduction
Installation
Getting started
Advanced setup
Parameters
Diagnostics
Terminal data

3.2.2 External-host mode

In this configuration the host controller is the DriveLink master, with the host controller handling all SLM calculations for initialisation. The Unidrive SP / Digitax ST functions as a Torque Loop Only (operating similar to a MultiAx drive).

Figure 3-4 External-Host mode external motion controller

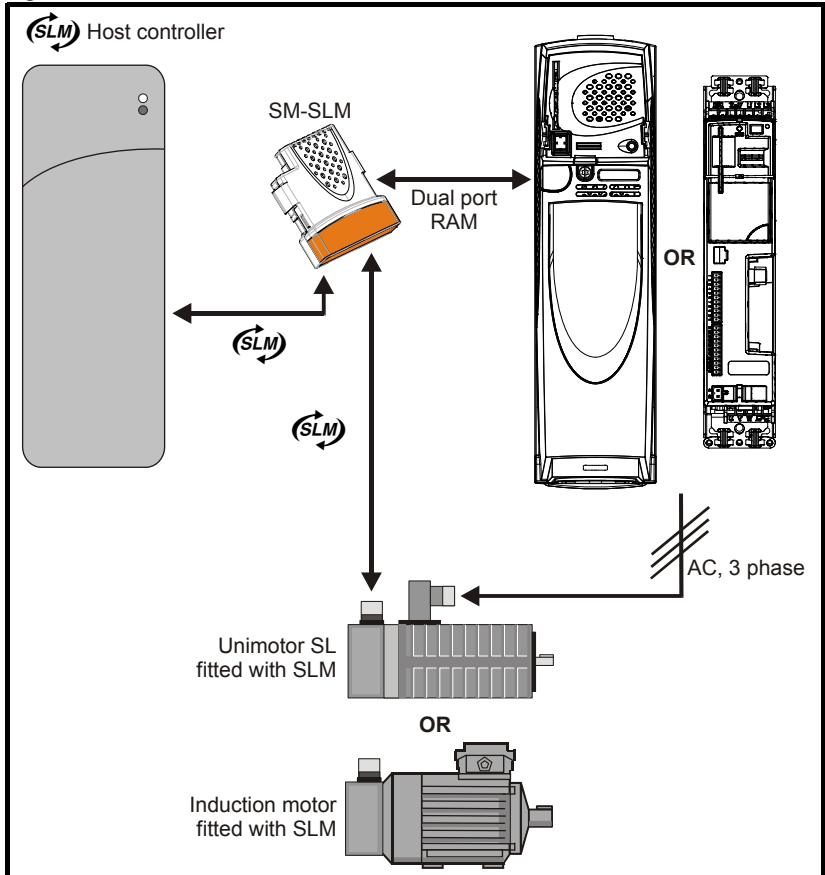

3.3 Solutions Module identification

The SM-SLM can be identified by:

1. The label located on the underside of the Solutions Module.
2. The color coding across the front of the Solutions Module. All Unidrive SP / Digitax ST Solutions Modules are color coded, with the SM-SLM being orange.

Figure 3-5 SM-SLM label

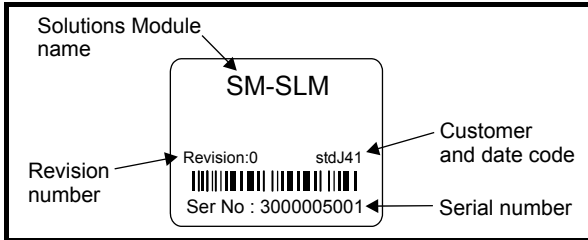

3.3.1 Date code format

The date code is split into two sections: a letter followed by a number.

The letter indicates the year, and the number indicates the week number (within the year) in which the Solutions Module was built.

The letters go in alphabetical order, starting with A in 1990 (B in 1991, C in 1992 etc.).

Example:

A date code of L35 would correspond to week 35 of year 2002.

3.4 Set-up parameters

With Unidrive SP, all user parameters associated to the SM-SLM can be found in either menu 15, 16, or 17. Each of menus 15, 16, and 17 refer to one of the available slots into which the SM-SLM can be fitted. See Figure 4-1 on page 13.

With Digitax ST / Unidrive SP0, all user parameters associated with the SM-SLM can be found in either menu 15 or 16. Each of menus 15 and 16 refer to one of the available slots into which the SM-SLM can be fitted. See Figure 4-1 on page 13 for details.

NOTE

When the SM-SLM is configured to operate in External-host mode, the host controller can use menu 81.xx to communicate to the current slot menu through the SLM host to Unidrive SP / Digitax ST drive parameter channel.

4 Installation

4.1 Installing the SM-SLM

4.1.1 Solutions Module slots



Before installing the SM-SLM, refer to Chapter 2 *Safety information* on page 5.

With Unidrive SP, there are three slots available into which the Solutions Module can be installed, as shown in Figure 4-1. The Solutions Module can be plugged into any one of these, but it is recommended that slot 3 be used for the first Solutions Module then slot 2 and finally slot 1. This ensures maximum mechanical support for the Solutions Module once fitted.

With Digitax ST/Unidrive SP0, there are two slots available into which the Solutions Module can be installed as shown in Figure 4-2 on page 13

NOTE

SLM and MC connections to SM-SLM are not hot swappable and could result in failure of SLM line drivers.

With Unidrive SP, if three Solutions Modules are fitted, the master becomes slot 1 over slot 2 and slot 3. If two Solutions Modules are fitted, the master becomes slot 2 over slot 3. Therefore, when operating with both an SM-SLM and an SM-Applications, the SM-SLM should be in slot 2 and the SM-Applications in slot 3.

With Digitax ST / Unidrive SP0, if two modules are fitted, the master becomes slot 1 over slot 2.

Figure 4-1 Location of slots 1, 2 and 3 on the Unidrive SP

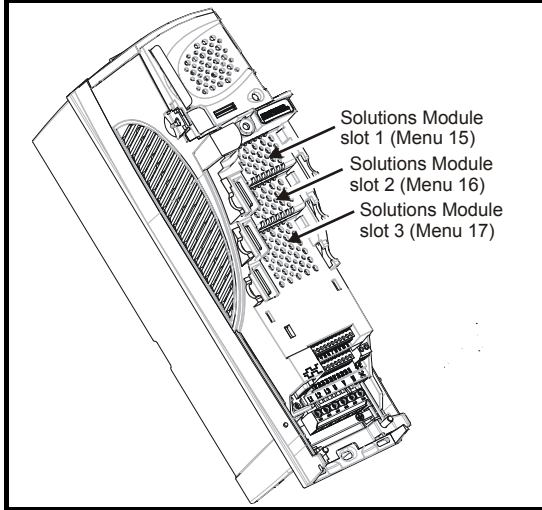
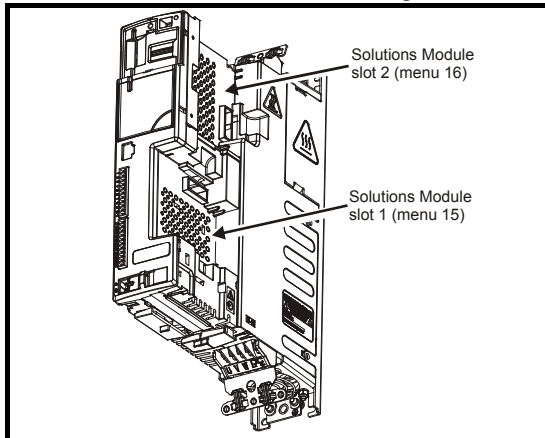

Figure 4-2 Location of slots 1 and 2 on the Digitax ST/Unidrive SP0



4.2 Installation

1. Before installing the SM-SLM in the Unidrive SP / Digitax ST, ensure the AC supply has been disconnected from the drive for at least 10 minutes.
2. Ensure that both the +24V, and +48V backup power supplies are disconnected from the drive for at least 10 minutes.
3. Check that the exterior of the SM-SLM is not damaged, and that the multi-way connector is free from dirt and debris.
4. Do not install a damaged or dirty SM-SLM in the drive.
5. Remove the terminal cover from the drive. (For removal / re-fitting instructions, see *Solutions Module Installation Sheet* provided with the Solutions Module.)
6. Position the drive connector of the SM-SLM over the connector of the appropriate slot in the drive and push downwards until it locks into place.

Figure 4-3 Fitting the SM-SLM to the Unidrive SP

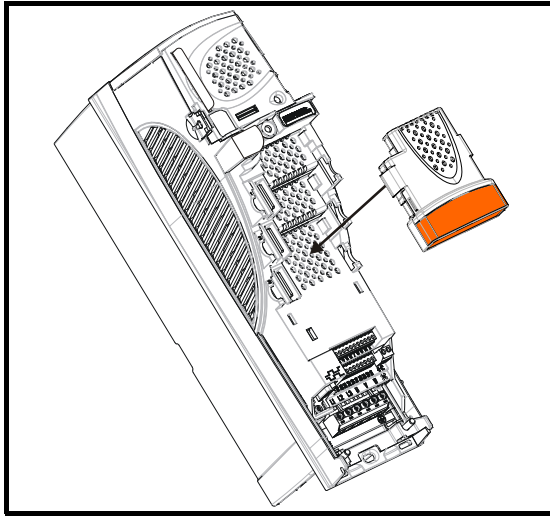
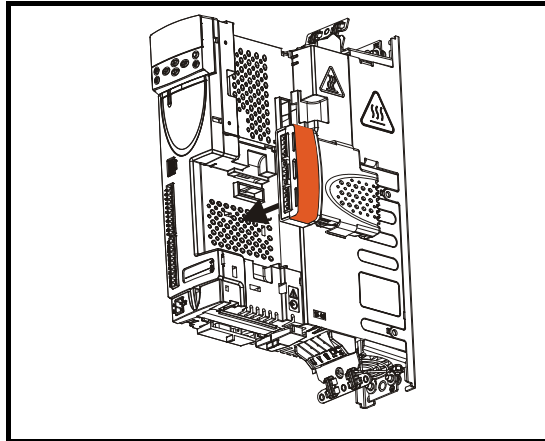

Figure 4-4 Fitting the SM-SLM to the Digitax ST/Unidrive SP0



7. Re-fit the terminal cover to the drive. (For removal / re-fitting instructions, see the *Solutions Module Installation Sheet* provided with the Solutions Module.)
8. Connect the AC supply to the drive.
9. Set Pr **0.49** to L2 to unlock read only security.
10. Check that Menu 15 (slot 1), 16 (slot 2), or 17 (slot 3) parameters are now available.
11. Check that Pr **15.01**, Pr **16.01** or Pr **17.01** show the correct code for the SM-SLM (code = 501).
12. If the checks in steps 10 and 11 fail, either the SM-SLM is not fully inserted, or the Solutions Module is faulty.
13. If a trip code is now present refer to Chapter 8 *Diagnostics* on page 52.

NOTE

Menu 17 (slot 3) is not available for the SM-SLM with Digitax ST / Unidrive SP0.

4.3 Terminal descriptions

Figure 4-5 Terminals

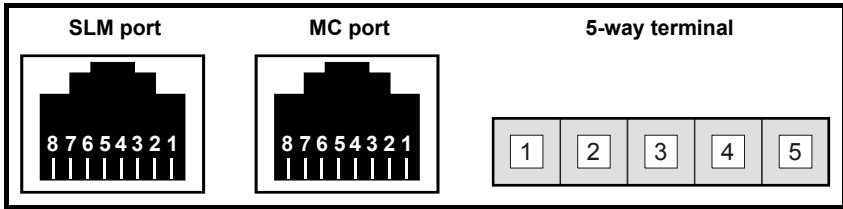

NOTE SLM and MC connections to SM-SLM are not hot swappable and could result in failure of SLM line drivers.

- NOTE**
- The SM-SLM does not support the Multi-drop standard.
 - The drive status line on both the SLM and MC ports is linked through the SLM and MC port. This is not used by the SM-SLM.
 - The screen connection points on both the SLM and MC ports and the 5-way terminal are all common and are connected internally on the SM-SLM to isolated 0V.
 - The enable inputs on the RJ45 connectors (SLM and MC) are used only in External-host mode to monitor the SLM, and are linked internally.

Connection from SM-SLM to the SLM module on the motor

Table 4-1 SLM Port

Terminal	Connection (SLM Port)
1	RS485 Drive-link COM
2	RS485 Drive-link COM/
3	Drive status (not used)
4	Enable (used as a monitor)
5	24Vdc (SLM)
6	Isolated 0V (SLM)
7	Not connected
8	Not connected
Screen	Screen

Connection for host (Motion controller)

Table 4-2 MC port

Terminal	Connection (MC Port)
1	RS485 Drive-link COM
2	RS485 Drive-link COM/
3	Drive status (not used)
4	Enable (used as monitor)
5	Not connected
6	Isolated 0V (SLM)
7	24Vdc (SLM)
8	Not connected
Screen	Screen

Connection for 24Vdc battery power supply

Table 4-3 5-way terminal

Terminal	Connection
1	Not used (dedicated for future product enhancements)
2	Not used (dedicated for future product enhancements)
3	Isolated 0V (screen) SLM
4	Battery 24V input
5	Isolated 0V (screen) SLM

4.4 Power supplies

4.4.1 24Vdc (SLM port T5)

The SM-SLM provides an isolated 16V \pm 1V power supply, 150mA, to power the SLM, this being diode protected. Alternatively an external power supply or battery input could be used.

4.4.2 Battery input (5-way terminal T4)

A battery input can be used even if a normal supply is provided from the host controller, due to line protection (diode) being present.

Voltage range: 17V to 22V

Nominal current: 65mA (one SLM)

Maximum current: 500mA

4.4.3 External power supply (MC port T7)

Where an external power supply is required, the following specification applies:

Voltage range: 24V to 30V

Nominal current: 65mA (one SLM)

Maximum current: 500mA

4.5 Wiring, Shield connections

4.5.1 Cable requirements

To ensure maximum noise immunity the shields must be terminated at the grounding bracket.

Figure 4-6 Fitting of grounding bracket for Unidrive SP (size 1 to 6)

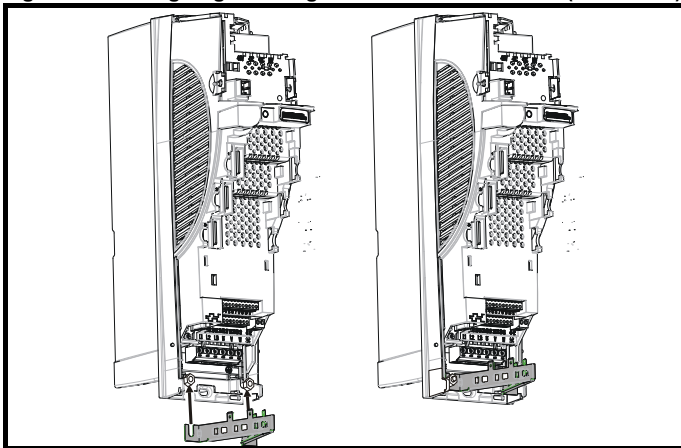

Loosen the ground connection nuts and slide the grounding bracket in the direction shown. Once in place, re-tighten the ground connection nuts.



The grounding bracket is secured using the power ground terminal of the drive. Ensure that the supply ground connection is secure after fitting / removing the grounding bracket. Failure to do so will result in the drive not being grounded.

A faston tab is located on the grounding bracket for the purpose of connecting the drive 0V to ground should the user require to do so.

Figure 4-7 Fitting of grounding bracket for Digitax ST / Unidrive SP0

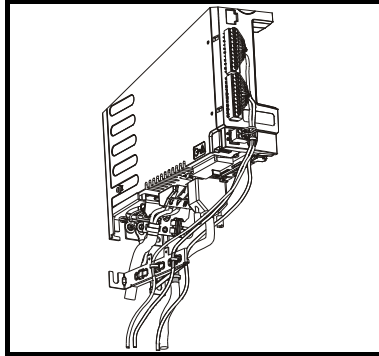
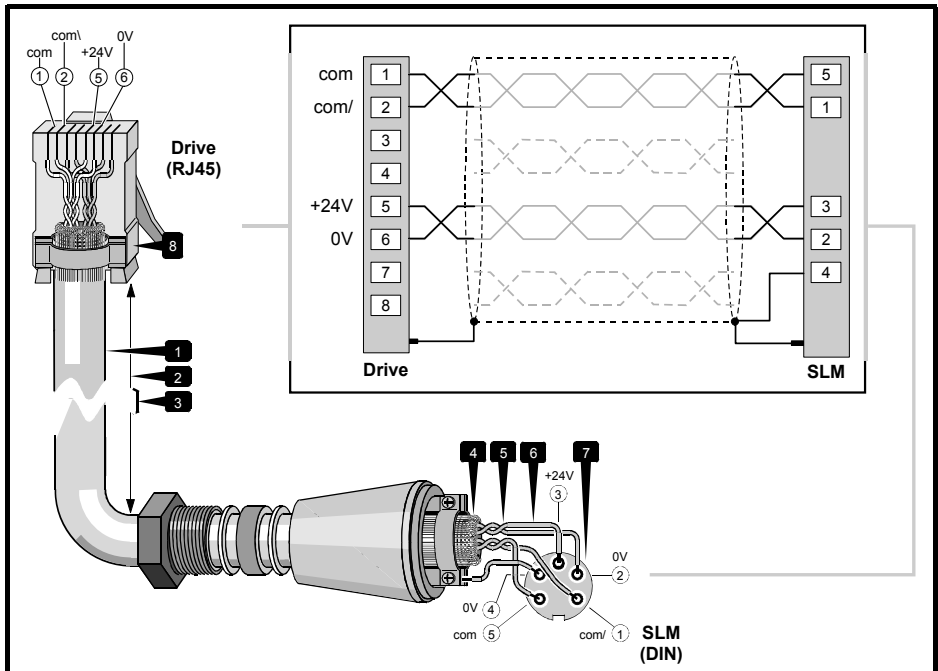
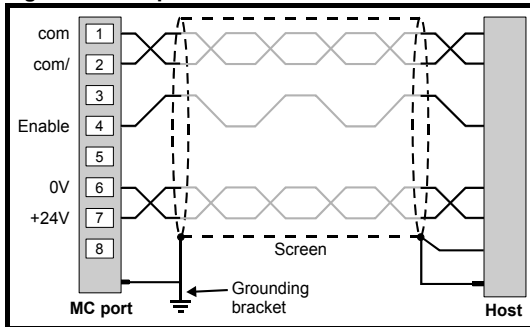

Figure 4-8 SLM port



1. 4-way shielded cable having an overall diameter not greater than 6.6mm ($\frac{1}{4}$ in)
2. Maximum length: 50m (165ft). Total length from SLM to Unidrive SP / Digitax ST to host controller.
3. Route the cable by the shortest convenient path and so that it is no closer than 300mm (1ft) from any power cable.
4. Overall shield of tinned copper braid. Comb out the braid at both ends, fold the strands back and trap them under the cable clamp to ensure good electrical contact with the connector shell.
5. The required twisted pairs connected to the DIN connector. (**Unwanted twisted pairs should be cut at each end and insulated to prevent inadvertent contact.**)
6. Make the wire ends as short as possible (this affects performance).
7. Amphenol C091 31D005 100 2 5-way screw-locking DIN connector meeting IP67.
8. Shielded RJ45 8-way plug

Figure 4-9 MC port



4.5.2 Recommended cable type (general)

The recommended cable type for feedback signals is a twisted pair, shielded with an overall shield as shown below (this being available with various numbers of ways, i.e 4-way, 8-way etc.).

Figure 4-10 Feedback cable, twisted pair

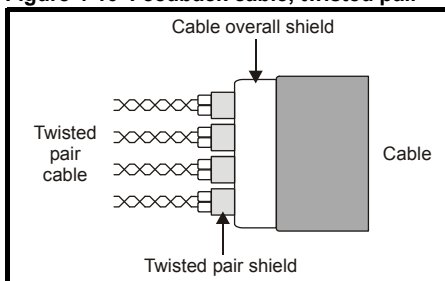

Using this type of cable also allows for the connection of the outer shield to ground and the inner shields to 0V alone at both drive and encoder end, when required.

NOTE

Ensure that feedback cables are kept as far away as possible from power cables and avoid parallel routing.

Figure 4-11 Feedback cable connections

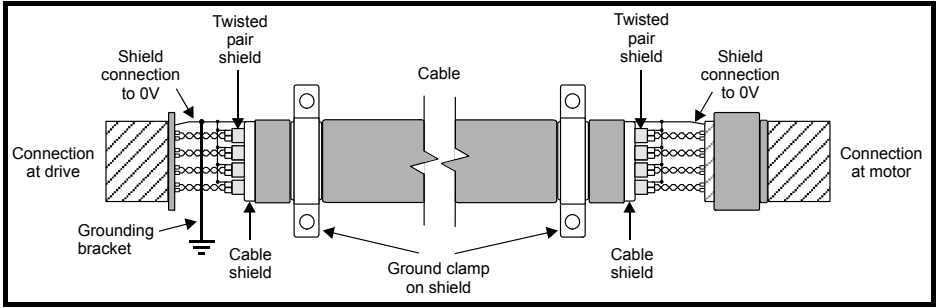

About this guide

Safety
information

Introduction

Installation

Getting started

Advanced setup

Parameters

Diagnostics

Terminal data

5 Getting started

5.1 Installation



WARNING

The control circuits are isolated from the power circuits in the drive by basic insulation only, as specified in IEC60664-1. The installer must ensure that the external control circuits are insulated from human contact by at least one layer of insulation rated for use at the AC supply voltage.

If the control circuits are to be connected to other circuits classified as Safety Extra Low Voltage (SELV) (e.g. to a personal computer) an additional isolating barrier must be included in order to maintain the SELV classification.

Encoder feedback and communications data is transmitted from an encoder as low voltage analog or digital signals. Ensure that electrical noise from the drive or motor does not adversely affect the encoder feedback. Ensure that the drive and motor are connected as per the instructions given in Chapter 4 *Electrical Installation* in the *Unidrive SP and Digitax ST User Guides*, and that the encoder feedback wiring and shielding recommendations are followed in section 4.5 *Wiring, Shield connections* on page 16.

NOTE

To enable the SM-SLM in any of the slots as the main feedback for the drive, Pr **3.26** *Speed feedback selector* must be set-up. If used as a reference Pr **3.26** is configured for the main feedback.

NOTE

Encoder initialisation will only occur when trips 1 through to 74 in Pr **x.50** Solutions Module error status are reset.

NOTE

When configuring the drive to operate with only main speed feedback connected to the SM-SLM, ensure the drive's error detection Pr **3.40** is set to 0 to avoid Enc2 trips.

NOTE

Pr **5.18** drive switching frequency must be selected as either 4kHz, 8kHz or 16kHz to allow Level 1 cycle time of 125µs.

NOTE

Pr **1.06** maximum reference clamp should be set appropriately for the motor being used.

5.2 Encoder only mode



In the default condition, the Unidrive SP will be configured to operate in torque control (Pr 4.11 = 1).

5.2.1 Detailed information

The SM-SLM allows interfacing between the drive and the SLM communication and control protocol. The Unidrive SP / Digitax ST provides the position, speed and torque loops.

The drive will consider the Solutions Module as a position feedback type option module so that the other Solutions Modules on the drive can use the position and speed, for example an SM-Applications.

NOTE In the default condition (External-host mode), the Unidrive SP will have been configured to operate in torque control (Pr 4.11 = 1). Return Pr 4.11 to 0 for speed control.

Figure 5-1 Encoder only mode data flow

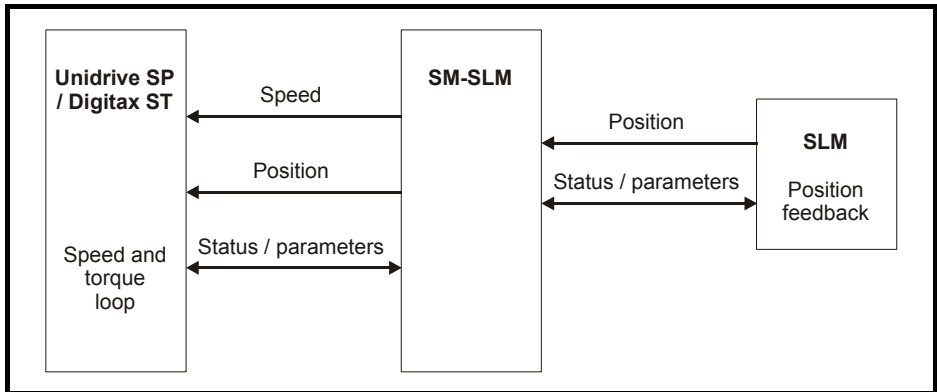

SLM (Speed loop motor), Encoder only mode

Action	Detail
Before power-up	Ensure: <ul style="list-style-type: none"> • Drive Secure Disable signal is not given (terminal 31) • Run signal is not given • Solutions Module is fitted in appropriate slot
Connection	Ensure: <ul style="list-style-type: none"> • SLM is connected to SLM port
Power up drive	If the drive trips see Chapter 8 <i>Diagnostics</i> on page 52
Error detection	Ensure: <ul style="list-style-type: none"> • If a drive encoder is not fitted, the error detection for the drive encoder port is disabled Pr 3.40 = 0
Slot identification	Identify which Solutions Module slot and menu are being used <ul style="list-style-type: none"> • Slot 1: Menu 15, Slot 2: Menu 16, Slot 3: Menu 17 (Unidrive SP only) Check Solutions Module ID code <ul style="list-style-type: none"> • Pr x.01 = 501
Select Solutions Module	Enter: <ul style="list-style-type: none"> • Speed feedback selector Pr 3.26 0 - Drive encoder, 1 - Slot 1 encoder, 2 - Slot 2 encoder, 3 - Slot 3 encoder (Unidrive SP only) Also refer to Pr x.30 on page 49
Switching frequency	Enter: <ul style="list-style-type: none"> • Ensure that the switching frequency selected (Pr 5.18) is either 4, 8 or 16kHz (125µs cycling) if not an SLx.Er 4 trip will be present. Also refer to Pr x.30 on page 49
Operating mode	Enter: <ul style="list-style-type: none"> • Select the SM-SLM operating mode 1, Enc.Only = 1 in Pr x.07 0 - HoSt - External-Host mode 1 - Enc.Only - Encoder only mode
Control mode	Enter: <ul style="list-style-type: none"> • At default, the Unidrive SP will be configured to operate in torque control. If speed control is required, Pr 4.11 must be configured. 0 - Speed control mode, 1 - Torque control, 2 - Torque control with speed override, 3 - Coiler / uncoiler mode, 4 - Speed control with torque feed forward
Sequencer state	Check: <ul style="list-style-type: none"> • Once all parameters have been set-up check the state of the sequencer in Pr x.14. This should be = 15 0 - Power up 1 - Normal mode comms set-up 2 - Normal mode comms set-up wait 3 - Axis initialisation 4 - Axis initialisation wait 5 - SP / ST mode comms set-up 6 - SP / ST mode comms set-up wait 15 - Running 16 - Trip
Axis initialised	Check: <ul style="list-style-type: none"> • Pr x.45 = ON indicates that the axis has been initialised and is ready to run
Save	Enter: <ul style="list-style-type: none"> • 1000 or 1001 (24Vdc, 48Vdc power supply) in Pr x.00

5.2.2 Parameter transfers

NOTE

For an induction motor with Unidrive SP, when normal performance mode parameters are loaded to the drive from the SLM, Pr 5.25 is reset to zero so that the power factor (Pr 5.10) can be written to. In order to set up Pr 5.25, either re-enter the previous value or perform an auto-tune.

The SLM EEPROM (CT Coder) present on the SLM allows for the following parameters to be either down-loaded to the SLM or up-loaded to the Unidrive SP / Digitax ST drive. In addition there are two defined parameter sets that are referred to as Performance modes:

1. Normal Performance
2. High Performance.

The following parameters are saved to the SLM EEPROM (CT Coder) in either the Normal or High Performance mode using Pr x.27 and Pr x.29 as detailed in this guide. Parameters can then be up-loaded to the Unidrive SP / Digitax ST drive using Pr x.26, Pr x.28 and Pr x.29.

Normal performance mode

Normal performance mode allows minimal parameters as listed to be down-loaded to or up-loaded from the Unidrive SP / Digitax ST providing normal performance from the drive.

Table 5-1 Normal performance parameters

Parameter	Servo motors	Induction motors (Unidrive SP only)
Pr 3.25	Motor flux angle	
Pr 4.13		Current controller Kp gain
Pr 4.14		Current controller Ki gain
Pr 5.06		Motor rated frequency
Pr 5.07	Motor rated current	
Pr 5.08	Motor rated speed	
Pr 5.09		Motor rated voltage
Pr 5.10		Power factor
Pr 5.11	Motor number of poles	
Pr 5.17		Stator resistance
Pr 5.24		Stator transient inductance

High performance mode

High performance mode allows all parameters listed to be down-loaded to or up-loaded from the Unidrive SP / Digitax ST providing high performance from the drive.

Table 5-2

Parameter	Servo Motors	Induction Motors (Unidrive SP only)
Pr 3.25	Motor flux angle	
Pr 4.13	Current controller Kp gain	
Pr 4.14	Current controller Ki gain	
Pr 5.06		Motor rated frequency
Pr 5.07	Motor rated current	
Pr 5.08	Motor rated speed	
Pr 5.09		Motor rated voltage
Pr 5.11	Motor number of poles	
Pr 5.17	Stator resistance	
Pr 5.24	Stator transient inductance	
Pr 5.25		Stator inductance
Pr 5.29		Motor saturation breakpoint 1
Pr 5.30		Motor saturation breakpoint 2

NOTE

Induction motors may not be used with Digitax ST drives

SLM (Speed loop motor), Encoder only mode

Reading data from the SLM EEPROM (CT Coder)

Action	Detail
Autotune mode	Enter: <ul style="list-style-type: none"> Autotune mode SLM to Unidrive SP / Digitax ST Pr x.26 = 1 0 - Idle, no tuning or set-up 1 - Read information from SLM EEPROM (CT Coder) to Unidrive SP / Digitax ST 2 - Idle, no tuning or set-up 3 - Idle, no tuning or set-up 4 - Reset the whole initialisation system (will hold sequencer in Reset)
Disable save mode	Enter: <ul style="list-style-type: none"> Disable the save mode Pr x.27 = 0
Parameters transferred	Enter: <ul style="list-style-type: none"> Select required parameter transfer Pr x.28 0 - MIN: Minimal parameters transferred so normal performance is possible 1 - MIN: Minimal parameters transferred so normal performance is possible 2 - FULL: All parameters transferred so high performance is possible <p>Cannot be carried out with the drive in run or stop</p>
Action save	Enter <ul style="list-style-type: none"> Carry out save Pr x.29 = On (1), when completed Pr x.29 = OFF (0)
Current loop gains	At the end of the data transfer from the SLM EEPROM (CT Coder) to the drive, an automatic set-up of the current loop gains is carried out (Pr 4.13 and Pr 4.14)
Sequencer state	Check: <ul style="list-style-type: none"> Once all parameters have been set-up, check the state of the sequencer in Pr x.14. This should be = 15 0 - Power-up 1 - Normal mode comms set-up 2 - Normal mode comms set-up wait 3 - Axis initialisation 4 - Axis initialisation wait 5 - SP / ST mode comms set-up 6 - SP / ST mode comms set-up wait 15 - Running 16 - Trip
Autotune mode	Enter: <ul style="list-style-type: none"> Pr x.26 = 0
Disable parameters transferred	Enter: <ul style="list-style-type: none"> Select required parameter transfer Pr x.28 = 0 0 - MIN: Minimal parameters transferred so normal performance is possible 1 - MIN: Minimal parameters transferred so normal performance is possible 2 - FULL: All parameters transferred so high performance is possible
Save	Enter: <ul style="list-style-type: none"> Set Pr x.00 = 1000 or 1001 (24Vdc, 48Vdc power supply) to save new data loaded to drive from SLM eeprom

About this guide

Safety information

Introduction

Installation

Getting started

Advanced setup

Parameters

Diagnostics

Terminal data

SLM (Speed loop motor), Encoder only mode

Saving data to SLM EEPROM (CT Coder)

Action	Detail
Disable autotune mode	Enter: <ul style="list-style-type: none"> Disable read information from SLM Pr x.26 = 0
Disable parameters transferred	Ensure: <ul style="list-style-type: none"> Disable parameters transferred, parameters to be transferred to drive Pr x.28 = 0
Save mode	Enter: <ul style="list-style-type: none"> Select required save mode Pr x.27 0 - Idle 1 - Parameters updated in SLM EEPROM (CT Coder) for normal performance 2 - Parameters updated in SLM EEPROM (CT Coder) for high performance Cannot be carried out with the drive in run or stop
Parameter save details	<p>NOTE The following details the parameters updated in the SLM Module EEPROM through both a Normal and High performance save Pr x.27 = 1 or 2</p> <p>Normal performance: Pr x.27 = 1</p> <p>Servo motors</p> <ul style="list-style-type: none"> Pr 5.07: Motor rated current Pr 5.08: Motor rated speed Pr 5.11: Motor number of poles Pr 3.25: Motor flux angle <p>Induction motors (Unidrive SP only)</p> <ul style="list-style-type: none"> Pr 5.07: Motor rated current Pr 5.08: Motor rated speed Pr 5.11: Motor number of poles Pr 5.06: Motor rated frequency Pr 5.09: Motor rated voltage Pr 5.17: Stator resistance Pr 5.24: Stator transient inductance Pr 4.13: Current controller Kp gain Pr 4.14: Current controller Ki gain Pr 5.10: Power factor <p>High performance: Pr x.27 = 2</p> <p>Servo motors</p> <ul style="list-style-type: none"> Pr 5.07: Motor rated current Pr 5.08: Motor rated speed Pr 5.11: Motor number of poles Pr 3.25: Motor flux angle Pr 5.09: Motor rated voltage Pr 5.17: Stator resistance Pr 5.24: Stator transient inductance Pr 4.13: Current controller Kp gain Pr 4.14: Current controller Ki gain <p>Induction motors (Unidrive SP only)</p> <ul style="list-style-type: none"> Pr 5.07: Motor rated current Pr 5.08: Motor rated speed Pr 5.11: Motor number of poles Pr 5.06: Motor rated frequency Pr 5.09: Motor rated voltage Pr 5.17: Stator resistance Pr 5.24: Stator transient inductance Pr 4.13: Current controller Kp gain Pr 4.14: Current controller Ki gain Pr 5.25: Stator inductance Pr 5.29: Motor saturation breakpoint 1 Pr 5.30: Motor saturation breakpoint 2
Action save	Enter <ul style="list-style-type: none"> Carry out save Pr x.29 = On (1), when completed Pr x.29 = OFF (0) and Pr x.27 automatically returns to zero (Idle)

5.3 External-host mode - Torque-amplifier only

5.3.1 Detailed information

In this mode, from the point of view of an SLM host position controller the Unidrive SP / Digitax ST drive acts as an unintelligent drive (Torque-amplifier). This allows the Unidrive SP / Digitax ST drive to function as a single axis MultiAx drive

The current loop of the Unidrive SP / Digitax ST drive is synchronized to the host controller, which is functioning as the position controller. The SLM provides the speed loop on the motor (as Unidrive SP / Digitax ST position and speed features are unavailable in External-host mode).

The control position is transferred every 125µs but the speed, full position and torque is only required every 250µs.

Motor protection is provided by the SLM, and so the motor current limits in the drive (Pr 4.05, Pr 4.06, Pr 4.07 and Pr 4.24) are set to the maximum allowed due to the motor current and drive current, up to a maximum of 330% motor current.

NOTE Pr 5.18 drive switching frequency must be selected as either 4kHz, 8kHz or 16kHz to allow Level 1 cycle time of 125µs. (Refer to the *Unidrive SP Advanced User Guide* for more details).

External hosts use 200% x drive rated current, but the maximum available current is 175% x drive rated current for Unidrive SP and 300% x drive rated current for Digitax ST. Therefore, SM-SLM sends SLM 100% nominal current instead of actual drive rated current so that host calculations do not need to change.

For Unidrive SP, SLM 100% nominal current = actual drive rated current * 1.75 / 2.

e.g. if drive rated current is 9.5A, SM-SLM will send $9.5 * 1.75 / 2 = 8.3A$ to the host.

For Digitax ST, SLM 100% nominal current = actual drive current * 3 / 2.

e.g. if drive rated current is 5.9A, SM-SLM will send $5.9 * 3 / 2 = 8.8A$ to the host.

NOTE The maximum drive current available remains unchanged.

Figure 5-2 External host mode data flow

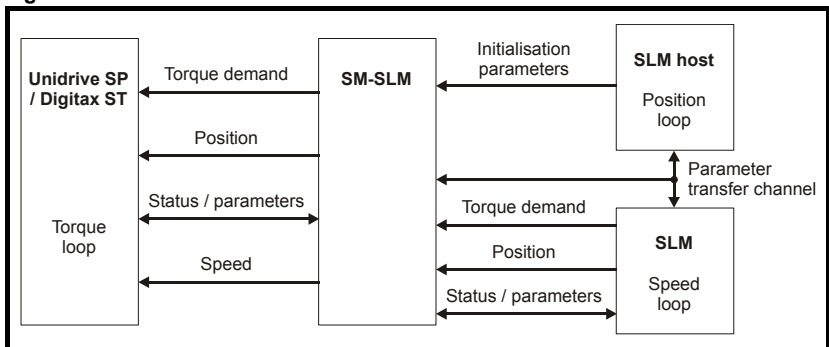

About this guide
Safety information
Introduction
Installation
Getting started
Advanced setup
Parameters
Diagnostics
Terminal data

5.3.2 Set-up

SLM (Speed loop motor), External-host mode	
Action	Detail
Before power-up	Ensure: <ul style="list-style-type: none"> • Drive Secure Disable signal is not given (terminal 31) • Run signal is not given • Solutions Module is fitted in appropriate slot
Connection	Ensure: <ul style="list-style-type: none"> • SLM is connected to SLM port • Host controller is connected to MC port
Power-up drive	If the drive trips see Chapter 9 <i>Terminal data</i> on page 56
Default (optional)	Enter: <ul style="list-style-type: none"> • Set drive defaults
Drive mode (optional)	Enter: <ul style="list-style-type: none"> • Select appropriate drive mode: Servo or closed loop vector (Unidrive SP only)
Operating mode	Enter: <ul style="list-style-type: none"> • Select the SM-SLM operating mode, HoSt = 0 through Pr x.07 0 - HoSt: External-host mode 1 - Enc.Only: Encoder only mode
Error detection	Ensure: <ul style="list-style-type: none"> • If a drive encoder is not fitted, the error detection for the drive encoder port is disabled Pr 3.40 = 0
Unidrive SP / Digitax ST thermistor set-up	Ensure: <ul style="list-style-type: none"> • If a motor thermistor is not fitted to the Unidrive SP / Digitax ST, the thermistor input is disabled Pr 7.15 = VOLT
Initialisation routine	Automatic initialisation <ul style="list-style-type: none"> • Initialisation carried out automatically by MC (motion controller) as detailed in section 5.3.4 <i>Motion controller initialisation routine for SM-SLM in External-host mode</i> on page 30

NOTE The following is taken care of by the motion controller.

Sequencer state	<p>Check:</p> <ul style="list-style-type: none"> • Once all parameters have been set-up check the state of the sequencer in Pr x.14. This should be = 15 0 - Power up 1 - Normal mode comms set-up 3 - Axis initialisation 5 - SP / ST mode comms set-up 7 - Wait for hardware enable 8 - Auto flux angle 9 - Wait for auto flux angle 10 - Complete auto flux angle 11 - Auto stator inductance 12 - Wait for auto stator inductance 13 - Auto current loop gains 14 - Wait for auto current loop gains 15 - Running 16 - Trip
-----------------	---

NOTE The following is taken care of by the motion controller.

SLM (Speed loop motor), External-host mode, Autotune	
Action	Detail
Parameters transferred	<p>Enter:</p> <ul style="list-style-type: none"> Select required parameter transfer Pr x.28 0 - NONE: No motor parameters have been sent to the Unidrive SP / Digitax ST 1 - MIN: Minimal parameters transferred so normal performance is possible 2 - FULL: All parameters transferred so high performance is possible
Autotune mode	<p>Enter</p> <ul style="list-style-type: none"> Autotune mode SLM to Unidrive SP / Digitax ST Pr x.26 0 - Idle: No tuning or set-up 1 - Parameter are valid or will be set externally <ul style="list-style-type: none"> Servo: Flux angle and all other parameters known - run only the current gains calculation Closed loop (Unidrive SP only): All parameters known - run only the current gains calculation 2 - Pulse test tuning <ul style="list-style-type: none"> Servo: Only flux angle known - run the pulse test to tune the current controller Closed loop (Unidrive SP only): Only field controller parameters known - run the pulse test to tune the current controller 3 - Full tuning (default) <ul style="list-style-type: none"> Servo: Run the minimal movement test to find flux angle and then run the pulse test to tune the current controller Closed loop (Unidrive SP only): Run the movement test ($\frac{2}{3}$ base speed) to tune the field controller and then run the pulse test to tune the current controller 4 - Reset the whole initialisation system including trigger SLM command 245 and 246 (will hold sequencer in Reset)
Action autotune and saving	<p>Enter</p> <ul style="list-style-type: none"> Carry out save Pr x.29 = 1
Sequencer state	<p>Check</p> <ul style="list-style-type: none"> Once all parameters have been set-up, check the state of the sequencer in Pr x.14. This should be = 15 0 - Power-up 1 - Normal mode comms set-up 3 - Axis initialisation 5 - SP / ST mode comms set-up 7 - Wait for hardware enable 8 - Auto flux angle 9 - Wait for auto flux angle 10 - Complete auto flux angle 11 - Auto stator inductance 12 - Wait for auto stator inductance 13 - Auto current loop gains 14 - Wait for auto current loop gains 15 - Running 16 - Trip
Axis initialised	<p>Check:</p> <ul style="list-style-type: none"> Pr x.45 = ON indicates that the axis has been initialised and is ready to run

5.3.3 Motion controller initialisation routine for Unidrive SP / Digitax ST

Communication will be restricted to the normal protocol until the host has ascertained that the drive is a Unidrive SP / Digitax ST drive and requested that the SLM module should use the Unidrive SP / Digitax ST mode (Full position and torque demand in the PWM position).

NOTE Only functions that are unique to Unidrive SP / Digitax ST are detailed below, i.e. additional to the initialisation routine in the *SLM Embedding Guide*.

About this guide

Safety information

Introduction

Installation

Getting started

Advanced setup

Parameters

Diagnostics

Terminal data

NOTE

The required Autotune and parameters transferred are carried out using both Pr **x.26** and Pr **x.28** which have to be set-up as required by user (*sp_par_tune* and *sp_par_trans*). The required motor type (*sp_mot_type*) also has to be set up, i.e. 2 = induction motor and 3 = servo motor.

5.3.4 Motion controller initialisation routine for SM-SLM in External-host mode

Header

(Motor type, autotune (Pr **x.26**) and parameters transferred (Pr **x.28**) are set here for each axis by user)

1. Set motor type (*sp_mot_type*) to same as Unidrive SP Pr **11.31**, or always to 3 if Digitax ST
 - 2: Induction motor
 - 3: Servo motor
2. Set Unidrive SP / Digitax ST autotune parameter (*sp_mot_tune*)
 - 0: IDLE (no tuning or set-up)
 - 1: All known (default - run current gains calculation only)
 - 2: Only flux angle known (run current gains calculation and pulse test)
 - 3: Nothing known (default - run current gains calculation, movement and pulse tests)
 - 4: RESET the whole initialisation system
3. Set Unidrive SP / Digitax ST parameters transferred (*sp_par_trans*)
 - 0: NONE (no parameters sent to Unidrive SP / Digitax ST)
 - 1: MIN (default - minimal parameters transferred, so normal performance is possible)
 - 2: FULL (all parameters have been transferred, so high performance is possible)
4. Set Unidrive SP / Digitax ST current loop gains override
 - Enable/disable current loop override
 - Set current loop kp value
 - Set current loop ki value

Main initialization routine

5. Reset sequencer
 - Check autotune and parameters transferred values are valid
 - Write Pr **81.26** = 4 (RESET the whole initialisation system)
 - Write Pr **81.29** = 1 (trigger the action)
 - Write Pr **81.30** = 1 (request the automatic drive parameter set-up)
6. Check Unidrive SP / Digitax ST Object
 - Calculate checksum for Unidrive SP / Digitax ST Object
 - Check Unidrive SP / Digitax ST Object list version is correct
7. Start the sequencer
 - Write Pr **81.26** = sp_par_tune (value set in header by user)
 - Write Pr **81.29** = 1 (trigger the action)
8. Write Pr **1.06** = motor base speed x 10
9. Change to SLM to page 2 (Unidrive SP / Digitax ST)
10. Set-up the Unidrive SP / Digitax ST
 - Check for drive enable signal (Pr **8.09** = 1)
 - Read Pr **11.31** (motor type)
 - Check motor type = sp_mot_type (value set in header by user)
 - Write Pr **81.28** = sp_par_trans (value set in header by user)
11. Autotune Unidrive SP / Digitax ST
 - Enable the axis (WDOG = ON only not SLM CMD253)
 - Read Pr **81.14** until it equals 15, 16 or maximum time elapsed
 - If Pr **81.14** = 16 (fault occurred):
 - Read and display Pr **81.50** (SM-SLM trip code)
 - If maximum time elapsed:
 - Read Pr **10.01** (drive healthy flag)
 - If Pr **10.01** = 1, read and display Pr **81.14** (sequencer status)
 - If Pr **10.01** <> 1, read and display Pr **10.20** (drive trip code)
12. If current loop override enabled:
 - Write Pr **4.13** = current loop kp (value set in header by user)
 - Write Pr **4.14** = current loop ki (value set in header by user)
 - Write Pr **5.26** = 1 (enable high dynamic performance)

5.4 Sequencer (Encoder only mode and External-host mode)

The sequencer status is used to determine in what state the start-up sequencer is.

The states used depend on the option module operating mode, the auto-tuning set-up and the load/save requests. The state can be useful in fault finding and for waiting for an operation to complete.

If the SM-SLM is in Encoder only mode and the sequencer state has not reached RUNNING or TRIP within 60 seconds, from the first pass through power-up after the sequencer has been restarted, then the option module will trip the drive with Pr **x.50** equal to 19.

NOTE Changing motor poles resets the SM-SLM (drive version 01.08.00 onwards) which causes the option module to reset the sequencer only if the sequencer was in the RUNNING state.

Sequencer State		Comments
0	Power-up	Start-up state
1	Normal mode comms set-up	Set-up of the normal SLM comms
2	Normal mode comms set-up wait	In External-host mode wait for SLM to change to page 1
3	Axis initialisation	SLM normal axis initialisation transfers
4	Axis initialisation wait	External-host mode, wait for SLM to get absolute position
5	SP/ST mode comms set-up	Conversion to Unidrive SP / Digitax ST type comms
6	SP/ST mode comms set-up wait	External-host mode, wait for SLM to change to page 2
7	Wait for hardware enable	Wait for the first initialised hardware enable
8	Auto flux angle	Start tuning the flux angle
9	Wait for auto flux angle	Wait for the tuning of the flux angle to finish
10	Complete auto flux angle	Complete the tuning of the flux angle
11	Auto Ls	Start tuning the stator transient inductance
12	Wait for auto Ls	Wait for stator transient inductance tuning to complete
13	Auto I gains	Calculate current controller gains (Pr 4.13 , Pr 4.14)
14	Wait for I gains	Wait for the current controller gains to be set
15	Running	Axis HE, tuned and enabled
16	Trip	Axis fault condition

Figure 5-3 Encoder only mode

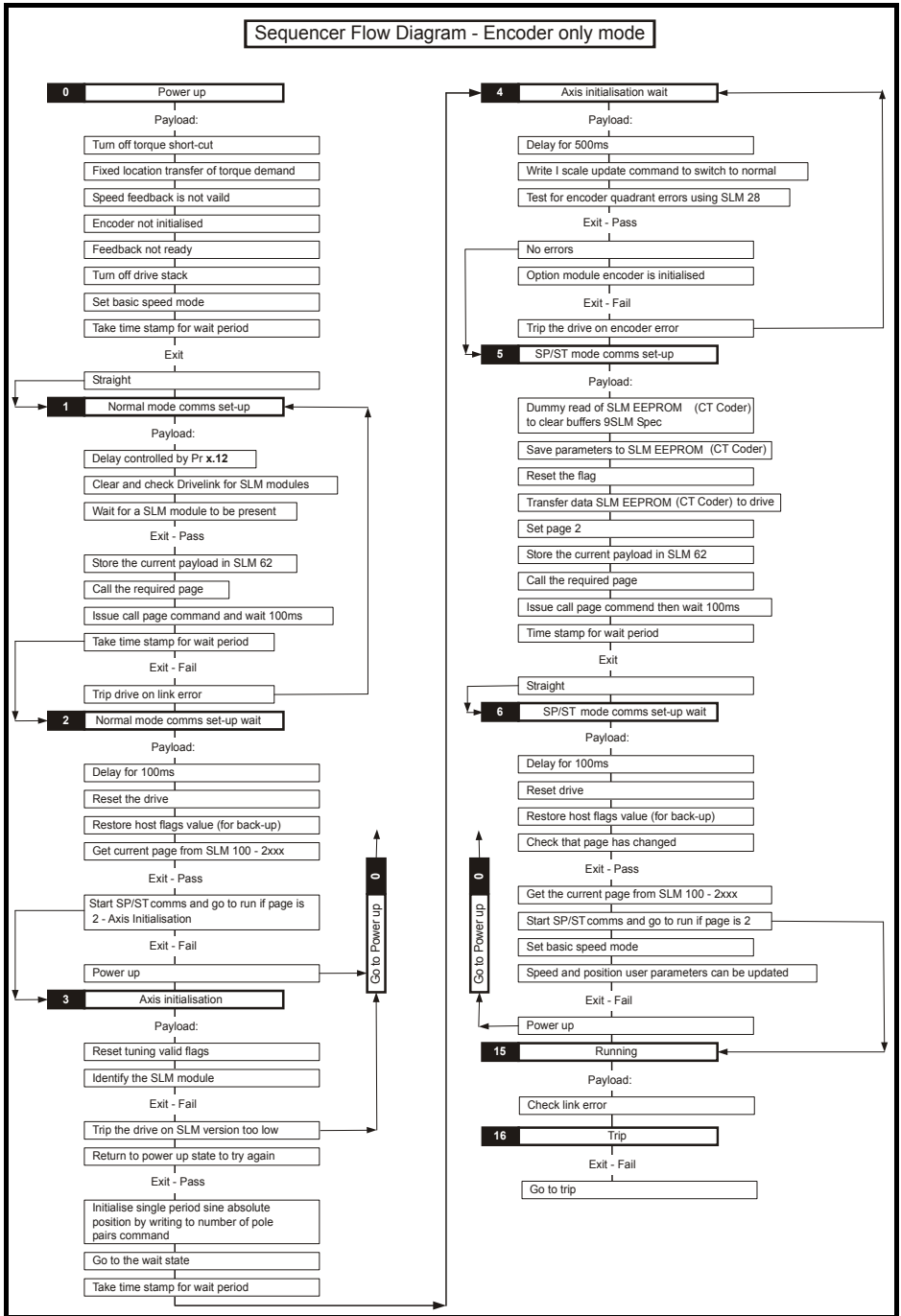

About this guide	Safety information	Introduction	Installation	Getting started	Advanced setup	Parameters	Diagnostics	Terminal data

Figure 5-4 External-host mode

Sequencer Flow Diagram - External host mode

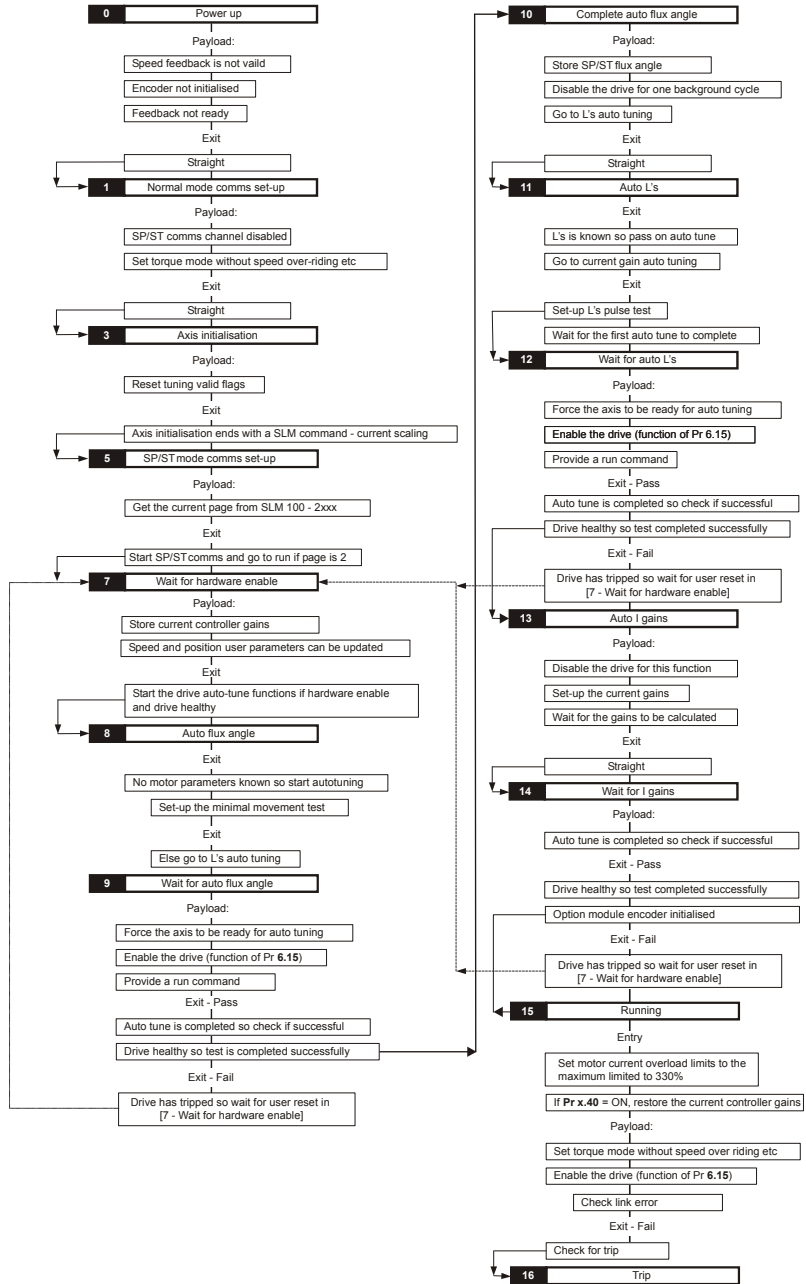

6 Advanced setup

6.1 SM-SLM and SLM EEPROM (CT Coder) set-up (Advanced user)

General

The SLM feedback device has an SLM EEPROM (CT Coder) which is used to store encoder offsets (Encoder Object) and can store a motor nameplate (Motor Object) and extra Unidrive SP / Digitax ST information (Unidrive SP / Digitax ST Object).

External-host mode or Encoder only mode with MOTOR OBJECT loading and saving

The SLM, when supplied from Control Techniques Dynamics or a Drive Centre, fitted to a servomotor or induction motor will have had the SLM EEPROM (CT Coder) programmed with the following information:

- Encoder Object (not user accessible, programmed by encoder manufacturer)
- Motor Object (user accessible, i.e. can be saved /read with SM-SLM in Encoder only mode)

Extra for induction motors and high performance servo motors:

- Unidrive SP / Digitax ST Object (user accessible, i.e. can be saved /read with SM-SLM in Encoder only mode)

For operation in External-host mode the drive is just a "Torque Slave" and therefore the motion controller requires all the correct information from the SLM in order to operate correctly.

For operation in Encoder only mode the SLM module is just a "position feedback device with a motor nameplate" and therefore the SM-SLM requires all the correct information from the SLM in order to operate correctly.

Encoder only mode without MOTOR OBJECT loading and saving

For operation with the SLM as purely a feedback device (Encoder only mode) the drive is programmed with the motor map and holds the autotune results. In this case the SLM EEPROM (CT Coder) does not have to be programmed with the Motor Object to operate correctly, however if not the SLM EEPROM (CT Coder) loading and saving will result in trips.

Considerations

There are situations where the Motor Object and the Unidrive SP / Digitax ST Object in the SLM EEPROM (CT Coder) may need to be altered by the user as follows:

1. When operating with a motor and SLM the user may wish to save any changes to either the Motor Object and the Unidrive SP / Digitax ST Object to the SLM EEPROM (CT Coder).
2. If exchanging an SLM between two motors having different motor maps and autotune results the SLM data will be incorrect. Swapping SLMs is not advised and can result in motor failure.



When operating with a Unidrive SP / Digitax ST drive, SM-SLM option module and SLM, the data stored in the SLM must be correct for the motor, which it is fitted to. Incorrect motor map and autotune results saved in an SLM can result in motor failure when read to the SP/ST drive via the SM-SLM option module or when using any other SLM servo product.

6.2 Altering the SLM EEPROM (CT Coder) Motor Object and Unidrive SP / Digitax ST Object

The SLM EEPROM (CT Coder) holding information can be altered using a Unidrive SP / Digitax ST and an SM-SLM.

NOTE The drive and SM-SLM must be autotuned in the required mode (Closed loop vector / Servo) firstly, and then the SLM EEPROM(CT Coder) data programmed with the SM-SLM configured for Encoder Only mode.

Altering the SLM EEPROM (CT Coder) Motor Object and Unidrive SP / Digitax ST Object	
Action	Detail
Motor map Induction motor <i>(Unidrive SP only)</i>	Enter: <ul style="list-style-type: none"> Set-up motor map details Pr 5.06 : Rated Frequency Pr 5.07 : Motor rated current Pr 5.08 : Motor rated speed (<i>unless defined by autotune</i>) Pr 5.09 : Motor rated voltage Pr 5.10 : Motor power factor (<i>unless defined by autotune</i>) Pr 5.11 : Motor number of poles
Motor map Servo motor	Enter: <ul style="list-style-type: none"> Set-up motor map details Pr 5.07 : Motor rated current Pr 5.08 : Motor rated speed Pr 5.09 : Motor rated voltage Pr 5.11 : Motor number of poles
Autotune Induction motor <i>(Unidrive SP only)</i>	Enter: <ul style="list-style-type: none"> Carry out autotune to provide following motor parameters and gain settings Pr 5.17 : Stator resistance Pr 5.24 : Stator transient inductance Pr 5.25 : Stator inductance Pr 5.29 : Motor saturation breakpoint 1 Pr 5.30 : Motor saturation breakpoint 2 Pr 4.13 : Current controller Kp gain (<i>set on completion of autotune</i>) Pr 4.14 : Current controller Ki gain (<i>set on completion of autotune</i>)
Autotune Servo motor	Enter: <ul style="list-style-type: none"> Carry out autotune to provide following motor parameters and gain settings Pr 5.17 : Stator resistance Pr 5.24 : Stator transient inductance Pr 4.13 : Current controller Kp gain (<i>set on completion of autotune</i>) Pr 4.14 : Current controller Ki gain (<i>set on completion of autotune</i>) Pr 3.25 : Motor flux angle
Operating mode	Enter: <ul style="list-style-type: none"> Select the SM-SLM operating mode 1, Enc.Only = 1 in Pr x.07 Refer to the section <i>Operating mode</i> on page 22.
Save mode	Enter: Set Pr x.26 to zero to disable loading <ul style="list-style-type: none"> Select required save mode Pr x.27 (recommended high performance: 2) 0 - Idle 1 - Parameters updated in SLM EEPROM (CT Coder) for normal performance 2 - Parameters updated in SLM EEPROM (CT Coder) for high performance Cannot be carried out with drive in run or stop
Action save	Enter: <ul style="list-style-type: none"> Carry out save Pr x.29 = On (1), when completed Pr x.29 = OFF (0) and Pr x.27 automatically returns to 0 (Idle)

All parameters for the motor map and autotune results have now been saved to the SLM EEPROM(CT Coder), these can be confirmed by reading the saved data back to the original parameters, Refer to the section *Reading data from the SLM EEPROM (CT Coder)* on page 25.

7 Parameters

7.1 Introduction

The parameters listed in this chapter are used for programming and monitoring the SM-SLM.

NOTE

The same parameter structure is available in menu 15, 16 and 17 referring to slots 1, 2 and 3 for Unidrive SP, or menu 15 and 16 referring to slots 1 and 2 for Digitax ST / Unidrive SP0.



Before attempting to adjust any parameters, refer to Chapter 2 *Safety information* on page 5.

Table 7-1 Key to parameter coding

Coding	Attribute
RW	Read/write: can be written by the user
RO	Read only: can only be read by the user
Bit	1 bit parameter
Bi	Bipolar parameter
Uni	Unipolar parameter
Txt	Text: the parameter uses text strings instead of numbers.
FI	Filtered: some parameters which can have rapidly changing values are filtered when displayed on the drive keypad for easy viewing.
DE	Destination: indicates that this parameter can be a destination parameter.
RA	Rating dependant: this parameter is likely to have different values and ranges with drives of different voltage and current ratings. This parameters is not transferred by smart cards when the rating of the destination drive is different from the source drive.
NC	Not cloned: not transferred to or from smart cards during cloning.
PT	Protected: cannot be used as a destination.
US	User save: saved in drive EEPROM when the user initiates a parameter save.
PS	Power-down save: automatically saved in drive EEPROM at power-down.

7.2 Single line descriptions

Parameter	Range($\hat{\updownarrow}$)		Default(\leftrightarrow)			Type						
	OL	CL	OL	VT	SV							
x.01	Solutions Module ID	0 to 599		501			RO	Uni			PT	US
x.02	Solutions Module software version	0.0 to 99.99					RO	Uni		NC	PT	
x.03	Speed	$\pm 40,000.0$ rpm					RO	Bi	FI	NC	PT	
x.04	Revolution counter	0 to 65,535 revolutions					RO	Uni	FI	NC	PT	
x.05	Position	0 to 65,535 ($1/2^{16}$ ths of a revolution)					RO	Uni	FI	NC	PT	
x.06	Fine position	0 to 65,535 ($1/2^{32}$ nds of a revolution)					RO	Uni	FI	NC	PT	
x.07	Operating mode	HoSt (0), Enc.Only (1)		HoSt (0)			RW	Txt				US
x.08	Marker pulse received indicator	OFF (0) or On (1)		OFF (0)			RO	Bit		NC		
x.09	SLM converted flux offset		SV > 0 to 65,535		0		RO	Uni				
x.10	Encoder lines per revolution	0 to 50,000		1024			RW	Uni				US
x.11	SLM software version	0.000 to 9.999		0.000			RO	Uni		NC	PT	
x.12	SLM power-up delay	0 to 5		1 (0.250s)			RW	Txt				US
x.13	Not used*											
x.14	Sequencer status	0 to 16					RO	Uni		NC	PT	
x.15	Not used*											
x.16	Not used*											
x.17	Not used*											
x.18	Not used*											
x.19	Feedback filter	0 to 5 (0 to 16 ms)		0			RW	Uni				US
x.20	Not used*											
x.21	Not used*											
x.22	Not used*											
x.23	Not used*											
x.24	Not used*											
x.25	Not used*											
x.26	Autotune mode	0 to 4		0			RW	Uni				US
x.27	Saving mode	0 to 2		0			RW	Uni				US
x.28	Parameters transferred	0 to 2		0			RW	Uni				US
x.29	Action the tuning and saving parameters	OFF (0) or On (1)		OFF (0)			RW	Txt				US
x.30	Automatic basic drive set-up request	0 to 1		0			RW	Uni				US
x.32	Not used*											
x.33	Not used*											
x.34	Not used*											
x.35	Not used*											
x.36	Not used*											
x.37	Not used*											
x.38	Not used*											
x.39	Not used*											
x.40	Freeze the current gains during auto-tuning	OFF(0) or On(1)		OFF(0)			RW	Bit		NC		US
x.41	Not used*											
x.42	Not used*											
x.43	Not used*											
x.44	Not used*											

Parameter	Range(⇅)		Default(⇔)			Type				
	OL	CL	OL	VT	SV					
x.45	Axis initialised	OFF (0) or On (1)					RO	Txt		PT
x.46	Not used*									
x.47	Not used*									
x.48	Not used*									
x.49	Lock position feedback	OFF (0) or On (1)		OFF (0)			RW	Bit		
x.50	Solutions Module error status	0 to 255					RO	Uni	NC	PT
x.51	Solutions Module software sub-version	0 to 99					RO	Uni	NC	PT

* Some of the parameters which are not used will be introduced in scheduled product enhancement.

RW	Read / Write	RO	Read only	Uni	Unipolar	Bi	Bi-polar
Bit	Bit parameter	Txt	Text string	Fl	Filtered	DE	Destination
NC	Not cloned	RA	Rating dependent	PT	Protected	US	User save
PS	Power down save						

About this guide
Safety information
Introduction
Installation
Getting started
Advanced setup
Parameters
Diagnostics
Terminal data

Figure 7-1 SM-SLM logic diagram

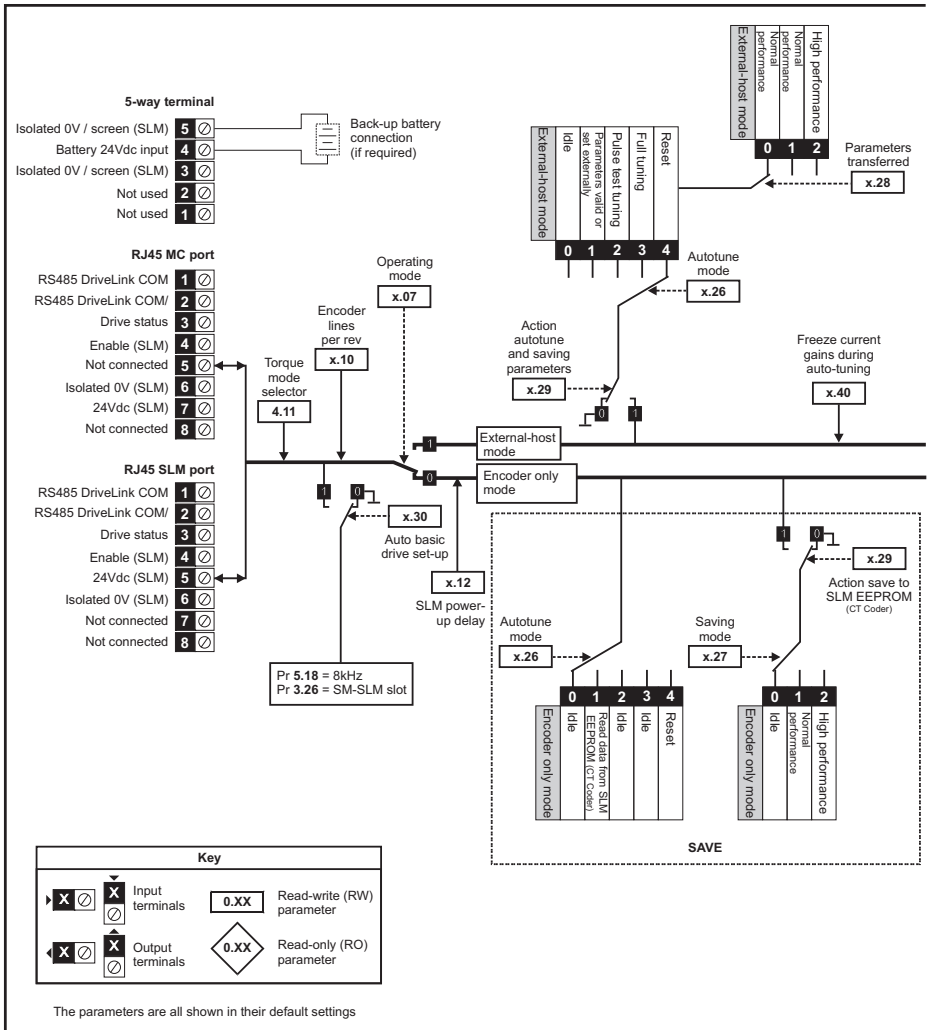

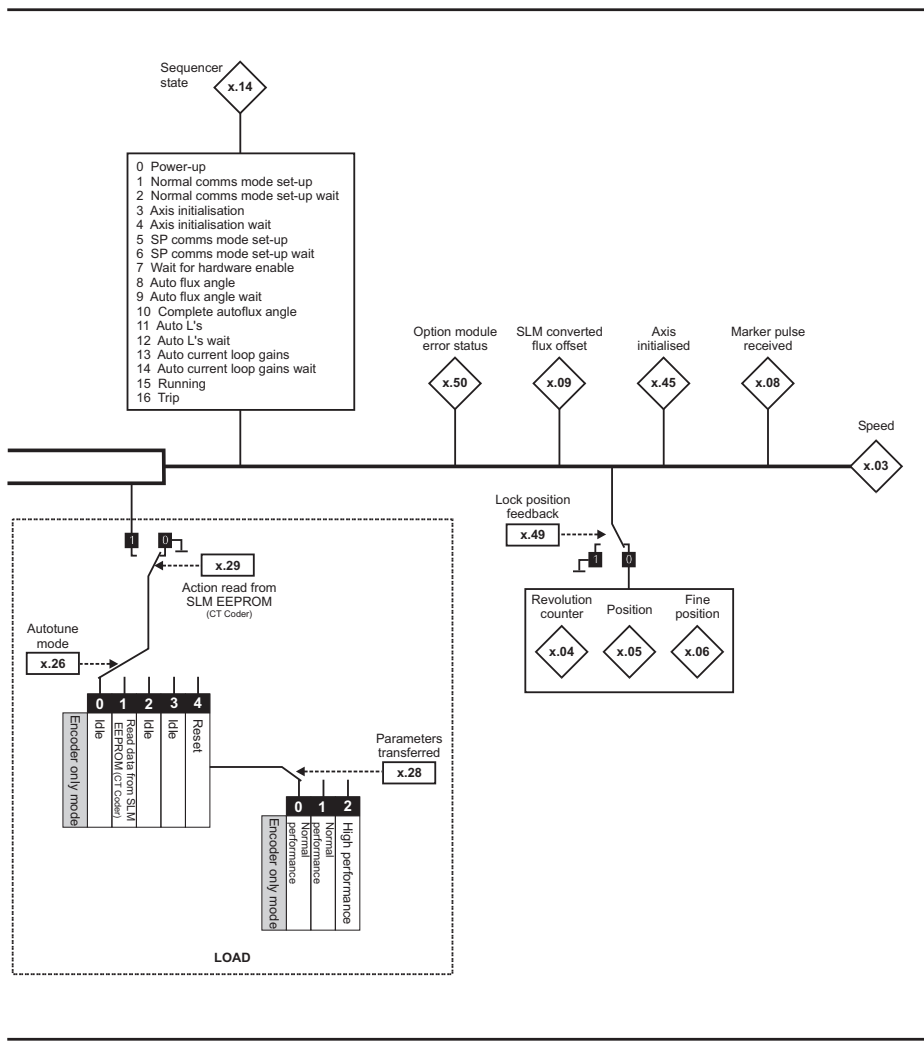

7.3 Parameter descriptions

x.01		Option ID code							
RO	Uni						PT	US	
↕	0 to 599				⇒	501			
Update rate: Write on power-up									

The menu for the relevant slot appears for the new Solutions Module category with the default parameter values for the new category. When no Solutions Module is fitted in the relevant slot this parameter is zero. When a Solutions Module is fitted this parameter displays the identification code as shown below.

Code	Solutions Module	Category	Dumb module
0	No Solutions Module fitted		
101	SM-Resolver	Feedback	✓
102	SM-Universal Encoder Plus	Feedback	
104	SM-Encoder Plus	Feedback	✓
201	SM-I/O Plus	Automation	✓
301	SM-Applications	Automation	
302	SM-Application Lite	Automation	
401	reserved	Fieldbus	
402	reserved	Fieldbus	
403	SM-Profibus DP	Fieldbus	
404	SM-Interbus	Fieldbus	
405	reserved	Fieldbus	
406	SM-CAN	Fieldbus	
407	SM-DeviceNet	Fieldbus	
408	SM-CANopen	Fieldbus	
501	SM-SLM	Feedback	

The new parameters values are not stored in the drive EEPROM until the user performs a parameter save. When parameters are saved by the user in the drive EEPROM the option code of the currently fitted Solutions Module is saved in the drive EEPROM. If the drive is subsequently powered-up with a different Solutions Module fitted, or no Solutions Module fitted where one was previously fitted, the drive gives a Slot.dF or SLot.nf trip.

x.02		Option software version							
RO	Uni						NC	PT	
↕	00.00 to 99.99				⇒				
Update rate: Write on power-up									

Unidrive SP (sizes 1 to 6) / Unidrive SPM

The software version of the Solutions Modules can be identified by looking at Pr **15.02** or Pr **16.02** or Pr **17.02** and Pr **15.51** or Pr **16.51** or Pr **17.51**.

Menu 15,16 or 17 is Solutions Module slot dependent with menu 17 being the lowest position nearest the control terminal connections.

The software version takes the form of xx.yy.zz, where Pr **15.02** or Pr **16.02** or Pr **17.02** displays xx.yy and Pr **15.51** or Pr **16.51** or Pr **17.51** displays zz (e.g. for software version 01.01.00 on a module in the middle Solutions Module slot, Pr **16.02** will display 1.01 and Pr **16.51** will display 0).

Unidrive SP (size 0) / Digitax ST

The software version of the Solutions Modules can be identified by looking at Pr **15.02** or Pr **16.02** and Pr **15.51** or Pr **16.51**.

Menu 15 or 16 is Solutions Module slot dependent with menu 15 (Unidrive SP size 0 and Digitax ST) being the position nearest the control terminal connections.

The software version takes the form of xx.yy.zz, where Pr **15.02** or Pr **16.02** displays xx.yy and Pr **15.51** or Pr **16.51** displays zz (e.g. for software version 01.01.00 for Unidrive SP size 0 and Digitax ST, the Solutions Module slot nearest the incoming supply terminals), Pr **16.02** will display 1.01 and Pr **16.51** will display 0).

x.03		Speed							
RO	Bi	FI				NC	PT		
⇕	±40,000.0 rpm				⇒				
Drive modes: External-host, Encoder only									
Update rate: 4ms write									

Provided the set-up parameters for the position feedback are correct this parameter shows the speed feedback in rpm. This parameter is filtered to increase readability.

x.04		Revolution counter							
RO	Uni	FI				NC	PT		
⇕	0 to 65535 revolutions				⇒				
Drive modes: External-host, Encoder only									
Update rate: 4ms write									

x.05		Position							
RO	Uni	FI				NC	PT		
⇕	0 to 65535 (1/2 ¹⁶ ths of a revolution)				⇒				
Drive modes: External-host, Encoder only									
Update rate: 4ms write									

x.06		Fine position							
RO	Uni	FI				NC	PT		
⇕	0 to 65535 (1/2 ³² nds of a revolution)				⇒				
Drive modes: External-host, Encoder only									
Update rate: 4ms write									

About this guide

Safety information

Introduction

Installation

Getting started

Advanced setup

Parameters

Diagnostics

Terminal data

These parameters effectively give the position with a resolution of $1/2^{32}$ ths of a revolution as a 48 bit number as shown below.

47	32	31	16	15	0
Revolutions			Position		Fine position

When the feedback device rotates by more than one revolution, the revolutions in Pr **x.04** increment or decrement in the form of a sixteen bit roll-over counter.

The marker offset corrects this position.

x.07		Operating mode							
RW	Txt							US	
↕	HoSt (0) to Enc.Only (1)			⇒	HoSt (0)				
Drive modes: External-host, Encoder only									
Update rate: Background read									

This parameter defines the mode of operation of the drive:

0 - **HoSt**: External-host mode (Torque amplifier only)

1 - **Enc.Only**: Encoder only mode

HoSt mode uses an external position controller host and an SM-SLM for the speed loop. The host controller will handle all SLM calculations for initialisation. The Unidrive SP / Digitax ST acts as torque amplifier similar in operation as the MultiAx drive.

Enc.Only mode uses the SLM module for speed feedback and nameplate data only.

x.08		Marker pulse, received indicator							
RO	Bit					NC			
↕	OFF (0) or On (1)			⇒	OFF (0)				
Drive modes: External-host, Encoder only									
Update rate: Background									

The encoder has a marker channel and this is used to correct the absolute position within a revolution after power-up. After passing through the marker this bit is set and the zero offset parameter is updated with the difference between zero of the encoder position and the marker. This error is due to the initial angle calculation using the single cycle SinCos. The power-up single cycle SinCos method has a maximum error of $\pm 3^\circ$.

x.09		SLM converted flux offset							
RO	Uni								
↕	0 to 65535			⇒	0				
Drive modes: External-host, Encoder only									
Update rate: Background read									

This parameter converts the drive phase angle (Pr **3.25**) into an SLM EEPROM (CT Coder) nameplate flux offset value. The drive is the electrical angle offset in degrees. The SLM flux offset is the mechanical offset in 65535 places per revolution offset by 120° .

x.10		Encoder lines per revolution								
RW	Uni							US		
↕		0 to 50000				⇒	1024			
Drive modes: External-host, Encoder only										
Update rate: Background read										

This parameter is used to set the mask used on the fine position sent from the SLM module to the Solutions Module. 1024 lines results in 6 extra bits of fine position information being used. This takes the full position resolution to 22 bits. A 2046 line encoder uses 7 extra bits of fine position etc.

x.11		SLM software version								
RO	Uni					NC	PT			
↕		0.000 to 9.999				⇒	0.000			
Drive modes: External-host, Encoder only										
Update rate: Background read										

Indicates the software version of the SLM module fitted to the motor. This is SLM Pr 100 which needs to have been transferred if in External-host mode. The format is p.vvv where p is the page and vvv is the software version of the page.

x.12		SLM power-up delay								
RW	Txt							US		
↕		0 to 5				⇒	1 (0.250 s)			
Drive modes: Encoder only										
Update rate: Background read										

This parameter specifies the time delay between the drive power-up and the SLM being available in 250ms units.

x.14		Sequencer status								
RO	ni					NC	PT			
↕		0 to 16				⇒				
Drive modes: External-host, Encoder only										
Update rate: Background write										

The sequencer status is used to determine in what state the start-up sequencer is. The states used depend on the option mode operating mode, the auto-tuning set-up and the load/save requests. The state can be useful in fault finding and for waiting for an operation to complete.

About this guide	Safety information	Introduction	Installation	Getting started	Advanced setup	Parameters	Diagnostics	Terminal data
------------------	--------------------	--------------	--------------	-----------------	----------------	------------	-------------	---------------

Sequencer State		Comments
0	Power-up	Start-up state
1	Normal mode comms set-up	Set-up of the normal SLM comms
2	Normal mode comms set-up wait	In External-host mode wait for SLM to change to page 1
3	Axis initialisation	SLM normal axis initialisation transfers
4	Axis initialisation wait	External-host mode, wait for SLM to get absolute position
5	SP/ST mode comms set-up	Conversion to Unidrive SP / Digitax ST type comms
6	SP/ST mode comms set-up wait	External-host mode, wait for SLM to change to page 2
7	Wait for hardware enable	Wait for the first initialised hardware enable
8	Auto flux angle	Start tuning the flux angle
9	Wait for auto flux angle	Wait for the tuning of the flux angle to finish
10	Complete auto flux angle	Complete the tuning of the flux angle
11	Auto Ls	Start tuning the stator transient inductance
12	Wait for auto Ls	Wait for stator transient inductance tuning to complete
13	Auto I gains	Calculate current controller gains (Pr 4.13, Pr 4.14)
14	Wait for I gains	Wait for the current controller gains to be set
15	Running	Axis HE, tuned and enabled
16	Trip	Axis fault condition

x.19		Feedback filter						
RW	Uni						US	
↕	0 (0), 1 (1), 2 (2), 3 (4), 4 (8), 5 (16) ms			⇒	0 (0)			
Drive modes: External-host, Encoder only								
Update rate: Background read								

A sliding window filter may be applied to the feedback. This is particularly useful in applications where the feedback is used to give speed feedback for the speed controller and where the load includes a high inertia, and so the speed controller gains are very high. Under these conditions, without a filter on the feedback, it is possible for the speed loop output to change constantly from one current limit to the other and lock the integral term of the speed controller.

x.26		Autotune mode						
RW	Uni						US	
↕	0 to 4			⇒	0			
Drive modes: External-host, Encoder only								
Update rate: Background								

Only read when Pr x.29 *Action request* is set high.

External-host mode:

0 - Idle: No tuning or set-up

1 - Parameters are valid or will be set externally

- SERVO - Flux angle and all other parameter known - run only the **current gains calculation**.
- CLOSED LOOP (Unidrive SP only) - All parameters known - run only the **current gains calculation**.

2 - Pulse test tuning

- SERVO - Only flux angle known - run the **pulse test** to tune the current controller.
- CLOSED LOOP (Unidrive SP only) - Only field controller parameters known - run the **pulse test** to tune the current controller.

3 - Full tuning

- SERVO - run the **minimal movement test** to find the flux angle and then run the **pulse test** to tune the current controller.
- CLOSED LOOP (Unidrive SP only) - run the **movement test (2/3 base speed)** to tune the field controller and then run the pulse test to tune the current controller.

4 - RESET the whole initialisation system including trigger SLM command 245 and 246.

NOTE 4 will hold the sequencer in reset.

NOTE The current gains (Pr 4.13 and Pr 4.14) will not be overwritten if Pr x.40 is set to On(1)

Encoder only mode:

0 - Idle: No tuning or set-up

1 - Read information from the SLM EEPROM (CT Coder) and update the Unidrive SP / Digitax ST parameters

NOTE The parameter set to use is determined by the value of *Parameters Transferred* (Pr x.28).

2 - Idle - no tuning or set-up

3 - Idle - no tuning or set-up

4 - RESET the whole initialisation system

NOTE 4 will hold the sequencer in reset.

x.27		Saving mode							
RW	Uni							US	
↕	0 to 2			⇒	0				
Drive modes: External-host, Encoder only									
Update rate: Background									

Only save when Pr x.29 *Action request* is set high. Only effective in Encoder only mode.

0 - IDLE

1 - Parameters updated in the SLM EEPROM (CT Coder) for normal performance

2 - Parameters updated in the SLM EEPROM (CT Coder) for high performance

About this guide
Safety information
Introduction
Installation
Getting started
Advanced setup
Parameters
Diagnostics
Terminal data

Servo motors:

Pr **x.27** = 1:

- Rated motor current Pr **5.07** (in 10th Amp units)
- Rated motor base speed Pr **5.08** (in rpm)
- Number of poles Pr **5.11**
- Flux angle Pr **3.25**

NOTE

Pr **3.25** is in electrical degrees. SLM EEPROM (CT Coder) data is in mechanical (65536 per rev) offset, which is minus Pr **3.25** converted by the number of poles the motor has.

Pr **x.27** = 2:

All for Pr **x.27** = 1 and -

- Rated motor voltage Pr **5.09**
- Stator resistance Pr **5.17** (per phase in 0.000) (delta (4/3 times per phase) in 0.00)
- Stator transient inductance Pr **5.24** (per phase in 0.000) (delta (4/3 times per phase) in 0.00)
- Current controller Kp gain Pr **4.13**
- Current controller Ki gain Pr **4.14**

Induction motors (Unidrive SP only):

Pr **x.27** = 1:

- Rated motor current Pr **5.07** (in 10th Amp units)
- Rated motor base speed Pr **5.08** (in rpm)
- Rated motor frequency Pr **5.06**
- Rated motor voltage Pr **5.09**
- Stator resistance Pr **5.17** (per phase in 0.000) (delta (4/3 times per phase) in 0.00)
- Stator transient inductance Pr **5.24** (per phase in 0.000) (delta (4/3 times per phase) in 0.00)
- Current controller Kp gain Pr **4.13**
- Current controller Ki gain Pr **4.14**
- Power factor Pr **5.10**

NOTE

When performing a minimal parameter transfer (Pr **x.27** = 1) with induction motors, Pr **5.25** is reset to 0 so that the power factor can be written to. In order to set up Pr **5.25**, either re-enter the previous value or perform an auto-tune.

Pr **x.27** = 2:

All for Pr **x.27** = 1 (except Pr **5.10**) and -

- L_s value Pr **5.25** (per phase in 0.00) (limit 655.35mH) (per phase in 0.00)
- Motor saturation point 1 Pr **5.29**
- Motor saturation point 2 Pr **5.30**

NOTE

In Encoder only mode, a parameter save cannot be performed with the drive in either RUN or STOP.

NOTE

Pr **x.27** automatically returns to 0 after the save has completed and Pr **x.29** has returned to 0.

x.28		Parameters transferred						
RW	Uni						US	
↕	0 to 2			⇒	0			
Drive modes: External-host, Encoder only								
Update rate: Background								

External-host mode:

- 0 - NONE: No motor parameters have been sent to the Unidrive SP / Digitax ST
- 1 - MIN: Minimal parameters have been transferred so normal performance is possible
- 2 - FULL: All parameters have been transferred so high performance is possible

NOTE The EEPROM CRC check performed by the host is listened to by the SM-SLM which stores parameters ready to transfer to the drive. When Pr x.28 is written to by the host, the appropriate stored EEPROM data is written to the drive parameters. If the host does not wish to use this function, nothing or 0 should be written to Pr x.28.

Encoder only mode:

If Autotune mode is equal to one:

- 0 - MIN: Minimal parameters to be transferred so normal performance is possible
- 1 - MIN: Minimal parameters to be transferred so normal performance is possible
- 2 - FULL: All parameters to be transferred so high performance is possible

When loading using Pr x.26 = 1, the parameter set loaded on power-up or restart depends on Pr x.28.

The parameter set is the same as was controlled by Pr x.27 when saving was performed.

NOTE In Encoder only mode, a parameter transfer cannot be performed with the drive in either RUN or STOP.

x.29		Action the tuning and saving parameters						
RW	Txt						US	
↕	OFF (0) or On (1)			⇒	OFF (0)			
Drive modes: External-host, Encoder only								
Update rate: Background								

Values of Pr x.26, Pr x.27 and Pr x.28 are read when Pr x.29 = 1. The sequencer is reset to POWER_UP. Pr x.29 is reset to 0 after the update - which is very fast.

x.30		Automatic basic drive set-up request						
RW	Uni						US	
↕	0 to 1			⇒	0			
Drive modes: External-host, Encoder only								
Update rate: Background								

Sets Pr 3.26 to the slot with the SLM module in it as primary feedback.

Pr 5.18 to 8kHz switching frequency.

These are the only drive parameters that require setting when the drive has been defaulted.

NOTE The user must set Pr 3.40 and Pr 7.15 appropriately.

This parameter is reset to zero by the Solutions Module on completion.

x.40		Freeze the current gains during auto-tuning								
RW	Bit						NC	US		
↕		OFF (0) or On (1)				⇒	OFF (0)			
Drive modes: External-host										
Update rate: Background										

In External-host mode, a high in this parameter stops the current gain recalculation at the end of the full parameter transfer and stores the current gains (Pr 4.13 and Pr 4.14) before the auto-tuning then returns the values after all auto-tuning has completed.

If a user knows that the SLM EEPROM gains are more appropriate than the auto-tuned gains, this parameter can be set to protect the full EEPROM transfer from recalculating the gains. Also, if a non-absolute encoder is connected to the SLM module, a complete auto-tune can be run on power up to determine the flux angle and motor parameters without changing the already commissioned current loop gains.

x.45		Axis initialised								
RO	Txt							PT		
↕		OFF (0) or On (1)				⇒	OFF (0)			
Drive modes: External-host, Encoder only										
Update rate: Background										

Indicates that the axis has been correctly initialised and is ready to run.

- Encoder only mode: Axis initialised active from sequencer status
- External-host mode: Axis initialised active from sequencer plus external motion controller

x.49		Lock position feedback								
RW	Bit									
↕						⇒				
Drive modes: External-host, Encoder only										
Update rate: Combined update time. SM-SLM adds 4ms to the combined update time										

If Pr x.49 is set to 1, Pr x.04, Pr x.05 and Pr x.06 are not updated. If this parameter is set to 0 Pr x.04, Pr x.05 and Pr x.06 are updated normally.

x.50		Solutions Module error status								
RO	Uni						NC	PT		
↕		0 to 255				⇒				
Update rate: Background write										

The error status is provided so that only one option error trip is required for each Solutions Module slot. If an error occurs, the reason for the error is written to this parameter and the drive may produce a 'SLX.Er' trip, where X is the slot number. A value of zero indicates that the Solutions Module has not detected an error, a non-zero value indicates that an error has been detected. (See Chapter 8 *Diagnostics* for the meaning of the values in this parameter.) When the drive is reset, this parameter is cleared for the relevant Solutions Module.

This Solutions Module includes a temperature monitoring circuit. If the PCB temperature exceeds 94°C, the drive fan is forced to operate at full speed (for a minimum of 10s). If the temperature falls below 94°C, the fan can operate normally again. If the PCB temperature exceeds 100°C, the drive will trip and the error status is set to 74.

x.51		Solutions Module software sub-version							
RO	Uni					NC	PT		
↕	0 to 99				⇒				
Update rate: Write on power-up									

Unidrive SP (sizes 1 to 6) / Unidrive SPM

The software version of the Solutions Modules can be identified by looking at Pr **15.02** or Pr **16.02** or Pr **17.02** and Pr **15.51** or Pr **16.51** or Pr **17.51**.

Menu 15,16 or 17 is Solutions Module slot dependent with menu 17 being the lowest position nearest the control terminal connections.

The software version takes the form of xx.yy.zz, where Pr **15.02** or Pr **16.02** or Pr **17.02** displays xx.yy and Pr **15.51** or Pr **16.51** or Pr **17.51** displays zz (e.g. for software version 01.01.00 on a module in the middle Solutions Module slot, Pr **16.02** will display 1.01 and Pr **16.51** will display 0).

Unidrive SP (size 0) / Digitax ST

The software version of the Solutions Modules can be identified by looking at Pr **15.02** or Pr **16.02** and Pr **15.51** or Pr **16.51**.

Menu 15 or 16 is Solutions Module slot dependent with menu 15 (Unidrive SP size 0 and Digitax ST) being the position nearest the control terminal connections.

The software version takes the form of xx.yy.zz, where Pr **15.02** or Pr **16.02** displays xx.yy and Pr **15.51** or Pr **16.51** displays zz (e.g. for software version 01.01.00 for Unidrive SP size 0 and Digitax ST, the Solutions Module slot nearest the incoming supply terminals), Pr **16.02** will display 1.01 and Pr **16.51** will display 0).

About this guide

Safety information

Introduction

Installation

Getting started

Advanced setup

Parameters

Diagnostics

Terminal data

8 Diagnostics

If the drive trips, the output is disabled so that the drive stops controlling the motor. The upper display indicates that a trip has occurred and the lower display shows the trip. Trips are listed alphabetically in Table 8-1 based on the trip indication shown on the drive display. Refer to Figure 8-1.

If a display is not used, the drive LED Status indicator will flash if the drive has tripped. Refer to Figure 8-2.

The trip indication can be read in Pr 10.20 providing a trip number.

8.1 Displaying the trip history

The drive retains a log of the last 10 trips that have occurred in Pr 10.20 to Pr 10.29 and the corresponding time for each trip in Pr 10.43 to Pr 10.51. The time of the trip is recorded from the powered-up clock (if Pr 6.28 = 0) or from the run time clock (if Pr 6.28 = 1).

Pr 10.20 is the most recent trip, or the current trip if the drive is in a trip condition (with the time of the trip stored in Pr 10.43). Pr 10.29 is the oldest trip (with the time of the trip stored in Pr 10.51). Each time a new trip occurs, all the parameters move down one, such that the current trip (and time) is stored in Pr 10.20 (and Pr 10.43) and the oldest trip (and time) is lost out of the bottom of the log.

If any parameter between Pr 10.20 and Pr 10.29 inclusive is read by serial communications, then the trip number in Table 8-1 is the value transmitted.

Figure 8-1 Unidrive SP keypad status modes

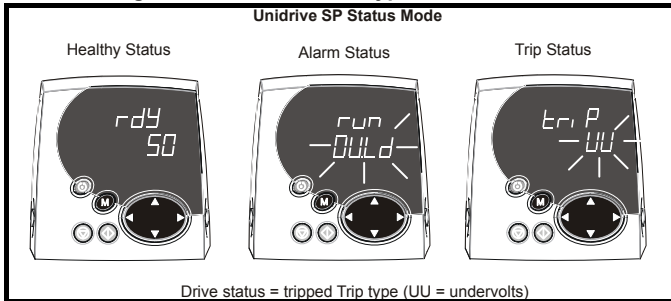

Figure 8-2 Unidrive SP location of the status LED

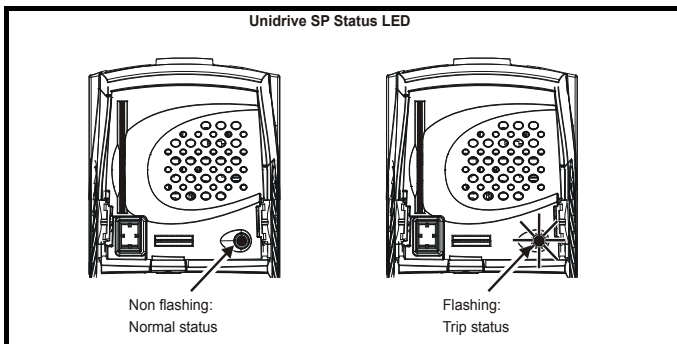

Figure 8-3 Digitax ST Keypad status modes

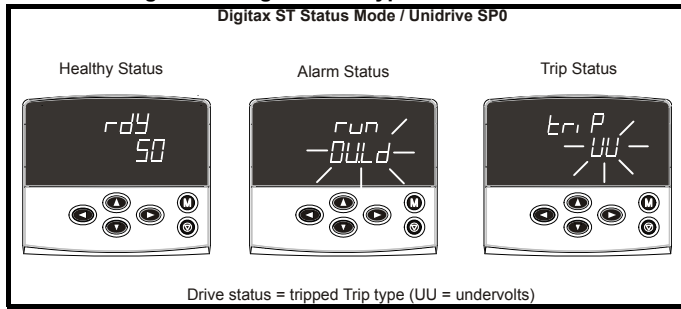
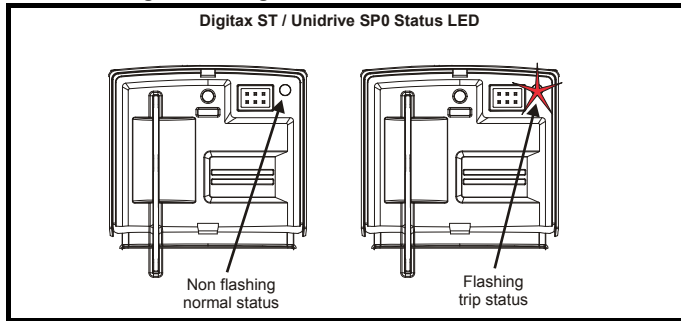



Figure 8-4 Digitax ST location of status LED



Any trip can be initiated by writing the relevant trip number to Pr **10.38**. If any trips shown as user trips are initiated the trip string is "txxx", where xxx is the trip number. Trips can be reset after 1.0s if the cause of the trip has been rectified.

A full list of drive trips can be found in the *Unidrive SP* and *Digitax ST User Guide*.

Table 8-1 Trip codes

Trip	Diagnosis
C.Optn	SMARTCARD trip: Solutions Modules fitted are different between source drive and destination drive
180	Ensure correct Solutions Modules are fitted Ensure Solutions Modules are in the same Solutions Module slot Press the red  reset button
ENP.Er	Data error from electronic nameplate stored in selected position feedback device
176	Replace feedback device
PS.24V	24V internal power supply overload
9	The total user load of the drive and Solutions Modules has exceeded the internal 24V power supply limit. The user load consists of the drive's digital outputs plus the SM-I/O Plus digital outputs, or the drive's main encoder supply plus the SM-SLM encoder supply. <ul style="list-style-type: none"> • Reduce load and reset • Provide an external 24V >50W power supply • Remove any Solutions Modules and reset

Trip	Diagnosis
SLX.dF	Solutions Module slot X trip: Solutions Module type fitted in slot X changed
204,209, 214	Save parameters and reset NOTE Trip 214 is not available for Digitax ST / Unidrive SP0
SLX.HF	Solutions Module slot X trip: Solutions Module X hardware fault
200,205, 210	Ensure Solutions Module is fitted correctly Return Solutions Module to supplier
SLX.nF	Solutions Module slot X trip: Solutions Module has been removed
203,208, 213	Ensure Solutions Module is fitted correctly Replace Solutions Module Save parameters and reset drive
SLX.tO	Solutions Module slot X trip: Solutions Module watchdog time-out
203,208, 211	Press reset. If the trip persists, contact the supplier of the drive.
SL.rtd	Solutions Module trip: Drive mode has changed and Solutions Module parameter routing is now incorrect
215	Press reset. If the trip persists, contact the supplier of the drive.

NOTE If the drive trips OI.AC when performing a full auto-tune (Pr x.26 = 3) with a servo motor, the default current loop gains may be too large. Therefore reduce the gains and the autotune will recalculate more appropriate values.

Trip	Diagnosis			
SLX.Er	Solutions Module slot X trip: Error detected with Solutions Module, where X is the slot number			
202, 207, 212	Pr x.50	Trip	Mode	Description
	0	No fault detected	Enc.only, External-host	
	1	Power supply OC	Enc.only, External-host	Power supply exceeded 150mA. (Derating to 100mA required at high temperatures (50°C ambient and above))
	2	SLM version low	Enc.only	SLM version too low. (Checked in Encoder only mode and trips if less then 4.02)
	3	Link error	Enc.only External-host	DriveLink error. (Trips if average is over 30)
	4	SW freq wrong	Enc.only, External-host	Switching frequency set to value other than 4, 8, or 16kHz (125µs cycle time required). (Checked in Encoder only mode and External-host mode).
	5	FB select wrong	Enc.only, External-host	Feedback source selection incorrect, should be set to Solutions Module slot with the SLM module. (Checked in Encoder only mode and External-host mode).
	6	Enc error	Enc.only	Encoder quadrant errors. (Checked in Encoder only mode).
	7	Motor instance	Enc.only	SLM EEPROM (CT Coder) motor object number of instances error, more than 30. (Checked in Encoder only mode).
	8	Motor list	Enc.only	SLM EEPROM (CT Coder) motor object list version error. (Checked in Encoder only mode).
	9	Perform instance	Enc.only	SLM EEPROM (CT Coder) performance object number of instances error. (Checked in Encoder only mode).
	10	P channel	Enc.only, External-host	Error in option module to drive parameter channel system. (Checked in Encoder only mode and External-host mode). SLM EEPROM data outside SM-SLM parameter range.
	11	Drive mode	Enc.only, External-host	Drive operating mode incompatible, not in closed loop or servo. (Checked in Encoder only mode and External-host mode).
	12	EEPROM write	Enc.only	Option module has a problem writing to the encoder SLM EEPROM (CT Coder). (Checked in Encoder only mode).
	13	Motor object type	Enc.only	SLM EEPROM (CT Coder) motor type is incorrect, servo object with drive in closed loop. (Checked in Encoder only mode).
	14	UNISP/Digitax ST object error	Enc.only	SLM EEPROM (CT Coder) Unidrive SP / Digitax ST object error or does not exist. (Checked in Encoder only mode).
	15	Encoder object CRC error	Enc.only	SLM EEPROM (CT Coder) encoder object CRC error. (Checked in Encoder only mode).
	16	Motor object CRC error	Enc.only	SLM EEPROM (CT Coder) motor object CRC error. (Checked in Encoder only mode).
	17	Performance object CRC error	Enc.only	SLM EEPROM (CT Coder) performance object CRC error. (Checked in Encoder only mode).
	18	UniSP/Digitax ST object CRC error	Enc.only	SLM EEPROM (CT Coder) Unidrive SP / Digitax ST object CRC error. (Checked in Encoder only mode).
	19	Sequencer timeout	Enc.only	Checks that the sequencer has got to RUN (15) within 60s of starting or restarting.
	74	OM thermistor trip	Enc.only, External-host	Option module internal over-temperature trip. (Checked in Encoder only mode and External-host mode).

About this guide
Safety information
Introduction
Installation
Getting started
Advanced setup
Parameters
Diagnostics
Terminal data

9 Terminal data

NOTE SLM and MC connections to SM-SLM are not hot swappable and could result in failure of SLM line drivers.

9.1 SLM port

1	RS485 DriveLink COM	
2	RS485 DriveLink COM/	
Type		Differential
Max output voltage range		-9V to +14V
Load impedance		100Ω
Maximum input voltage range		-9V to +14V
Input impedance		560Ω
Maximum data rate		2.5Mb/s
Maximum cable length		50m (total length from SLM to Unidrive SP/Digitax ST to host)
3	Drive status	Not used. Only hard wire link between pins 3 of MC and SLM ports
4	Enable (SLM)	Used as a monitor, e.g. run permit (from host)
5	24Vdc (SLM)	16Vdc ±1V Nominal current: 65mA Maximum current: 150mA
6	Isolated 0V (SLM)	
7	Not connected	
8	Not connected	
Shield		

9.2 MC port

1	RS485 DriveLink COM	
2	RS485 DriveLink COM/	
Type		Differential
Max output voltage range		-9V to +14V
Load impedance		100Ω
Maximum input voltage range		-9V to +14V
Input impedance		560Ω
Maximum data rate		2.5Mb/s
Maximum cable length		50m (total length from SLM to Unidrive SP/Digitax ST to host)
3	Drive status	Not used. Only hard wire link between pins 3 of MC and SLM ports
4	Enable (SLM)	Used as a monitor, e.g. run permit (from host)
5	Not connected	
6	Isolated 0V (SLM)	
7	24Vdc (SLM)	16Vdc ±1V Nominal current: 65mA Maximum current: 150mA
8	Not connected	
Shield		

9.3 5-way terminal

1	Freeze	Not used
2	Freeze/	Not used
3	Isolated 0V (shield) SLM	
4	Battery 24V input	17Vdc to 22Vdc 1 x SLM current: 65mA Nominal current: 150mA Maximum current: 500mA
5	Isolated 0V (shield) SLM	

About this guide
Safety information
Introduction
Installation
Getting started
Advanced setup
Parameters
Diagnostics
Terminal data

Index

Numerics

24Vdc specification 16

A

Autotune mode 46

Axis initialised 50

C

Cable (recommended) 18

Cable length 7

Cautions 5

Code 14

Colour coding 11

Compliance 6

Connections 15

Control position 27

D

Diagnostics 52

E

Electrical noise 20

Electrical safety 5

Enc.Only 44

Encoder only mode 7, 8

Environmental limits 6

External-host mode 7, 10, 27

F

Features 7

Feedback cable 18

Feedback cable connections 19

Filter 46

G

Grounding bracket 16

H

High performance 24

HoSt 44

Host controller 28

I

Induction motor 8, 9, 10

Installation 13, 20

K

Keypad status modes 52

L

Logic diagram 40

M	
Main feedback	20
Mask	45
MC port	15
Menu 81	11
Motion controller	10
N	
newlink op501.prXX05	43
Noise immunity	16
Normal performance	23
O	
Option ID code	42
P	
Parameter - single line descriptions	38
Parameter coding	37
Parameter descriptions	42
Parameter structure	37
Parameter transfers	23
Parameters - adjusting	6
Power cables	18
Power-up delay	45
S	
Safety of personnel	5
Saving mode	47
SECURE DISABLE	5
Sequencer	32
Set-up parameters	11
Shield connections	16
SLM Port	15
Slots	12
Software sub-version	51
Software version	42, 45
Solutions Module identification	11
Switching frequency	20
T	
Temperature monitoring circuit	51
Time delay	45
Trip history	52
W	
Warnings	5



0471-0035-06